



STPAUL.GOV



CITY OF SAINT PAUL PUBLIC WORKS
March 11, 2025

Wheelock/Grotto



WHEELOCK/GROTTO PHASE 1

Phase 1 to begin construction in early summer of 2025, to be completed by November of 2025.

Project Manager – Barb Mundahl
651-266-6112
Barbara.Mundahl@ci.stpaul.mn.us

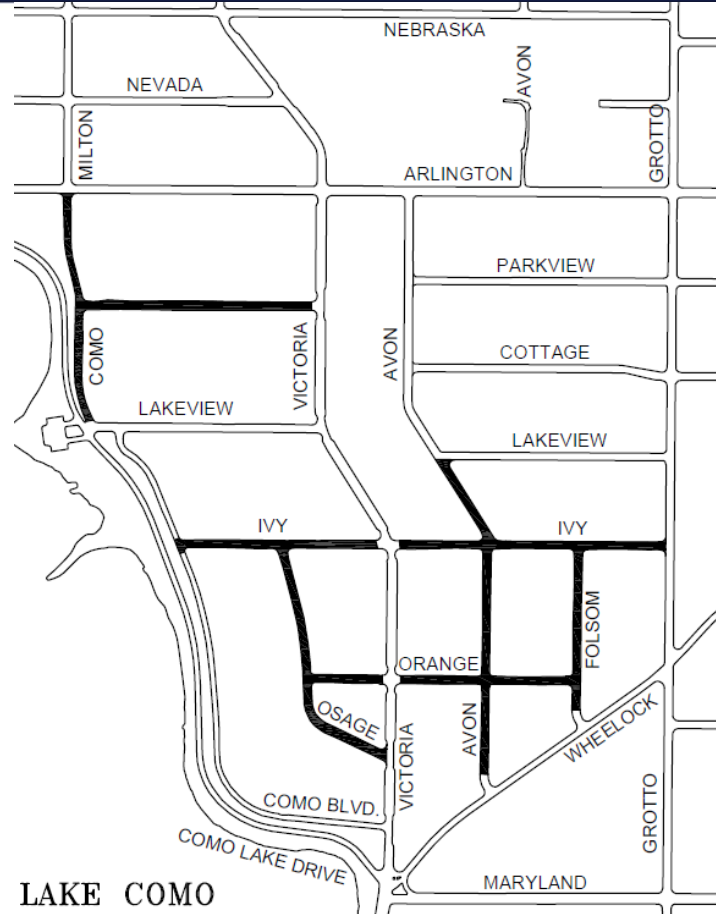

LAKE COMO



Project Improvements

- New concrete curb and gutter
- New roadway pavement
- Utility upgrades including new watermain, storm and sanitary sewer mains.
- Sidewalk replacement and new sidewalks where none exist
- ADA-compliant pedestrian ramps
- Lantern style Street Lighting
- Tree Planting



WHEELOCK/GROTTO PHASE 1

- **Engineering staff analyzed the survey data of existing topographic conditions and have made revised recommendations for placement of new sidewalk within the project area.**
- **Current proposal follows existing Sidewalk Policy.**
- **Recommendations for new sidewalk on one side only for Parkview, Ivy, Orange and E. Como Boulevard.**
- **Recommendations for sidewalk on both sides of Osage, Avon and Folsom.**
- **Existing walks on Osage, Ivy, Avon and Folsom will be replaced to address non-ADA compliance, damaged or tree heaved panels.**





WHEELLOCK/GROTTO PHASE 1 - PARKVIEW





WHEELLOCK/GROTTO PHASE 1 - IVY

SOME GRADE CHALLENGES AND ENCROACHMENTS ON THE SOUTH SIDE OF IVY ST. WOULD PUSH PROPOSED SIDEWALK CLOSER TO OR DIRECTLY BEHIND THE CURB LEAVING REDUCED OR NO BOULEVARD FOR SNOW STORAGE OR FUTURE TREE PLANTING.
 SOME EXISTING SIDEWALK ON THE NORTH SIDE OF STREET.
 RECOMMEND SIDEWALK CONSTRUCTION ON NORTH SIDE ONLY.

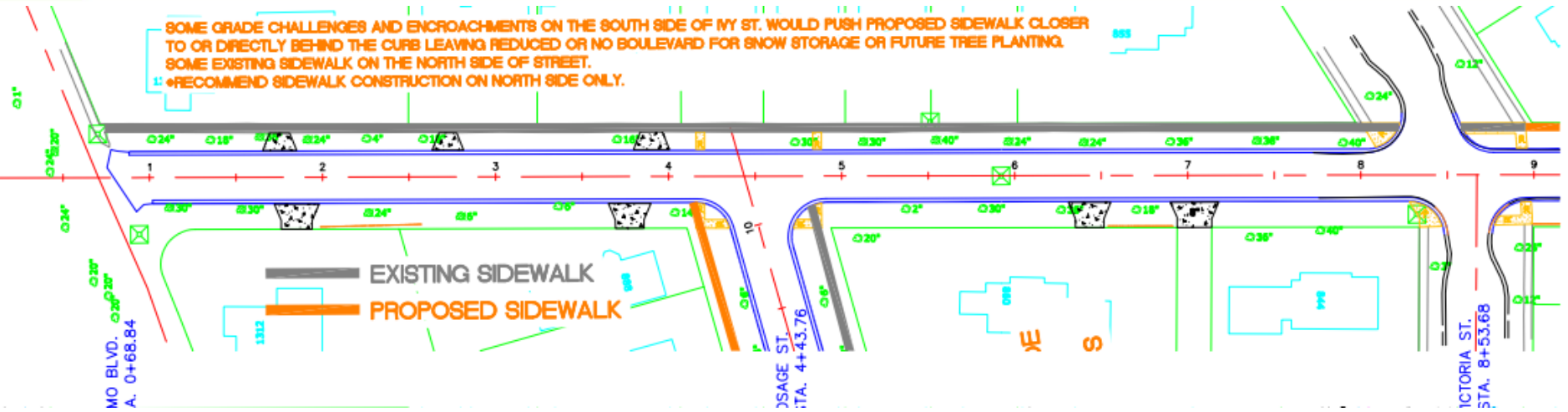

SOME GRADE CHALLENGES AND ENCROACHMENTS ON THE SOUTH SIDE OF IVY ST. WOULD PUSH PROPOSED SIDEWALK CLOSER TO OR DIRECTLY BEHIND THE CURB LEAVING REDUCED OR NO BOULEVARD FOR SNOW STORAGE OR FUTURE TREE PLANTING.
 SOME EXISTING SIDEWALK ON THE NORTH SIDE OF STREET.
 RECOMMEND SIDEWALK CONSTRUCTION ON NORTH SIDE ONLY.

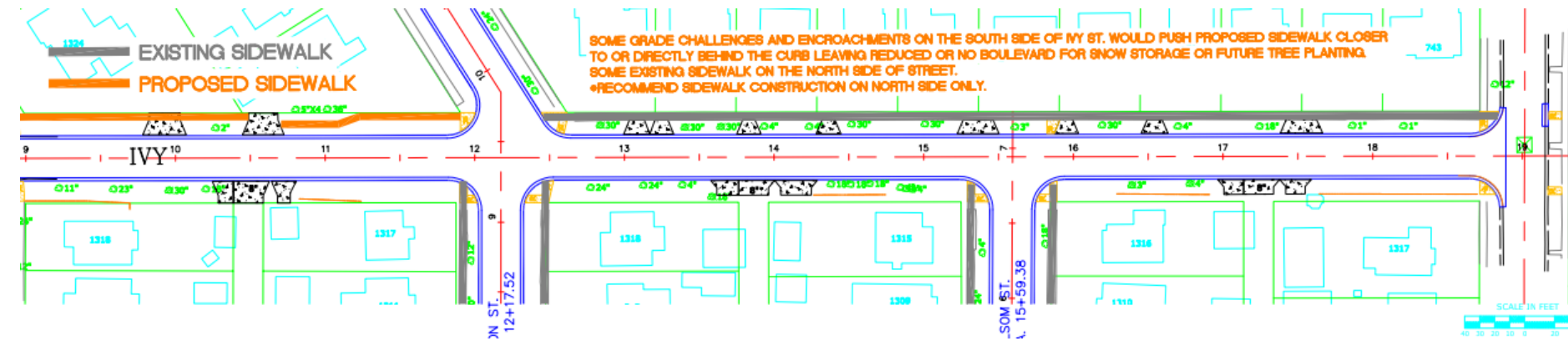



WHEELLOCK/GROTTO PHASE 1 – ORANGE ST.

SIGNIFICANT GRADE CHALLENGES AND ENCROACHMENTS ON THE SOUTH SIDE OF ORANGE ST. WOULD PUSH PROPOSED SIDEWALK CLOSER TO OR DIRECTLY BEHIND THE CURB LEAVING REDUCED OR NO BOULEVARD FOR SNOW STORAGE OR FUTURE TREE PLANTING. SOME EXISTING SIDEWALK ON THE NORTH SIDE OF STREET.
•RECOMMEND FILLING IN SIDEWALK GAPS ON NORTH SIDE ONLY.

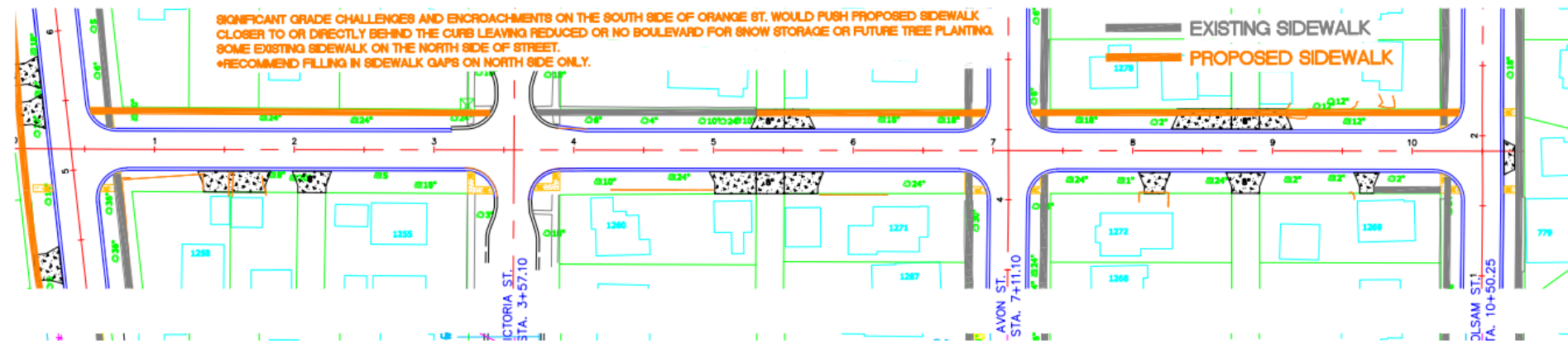



WHEELLOCK/GROTTO PHASE 1 – E. COMO BLVD.

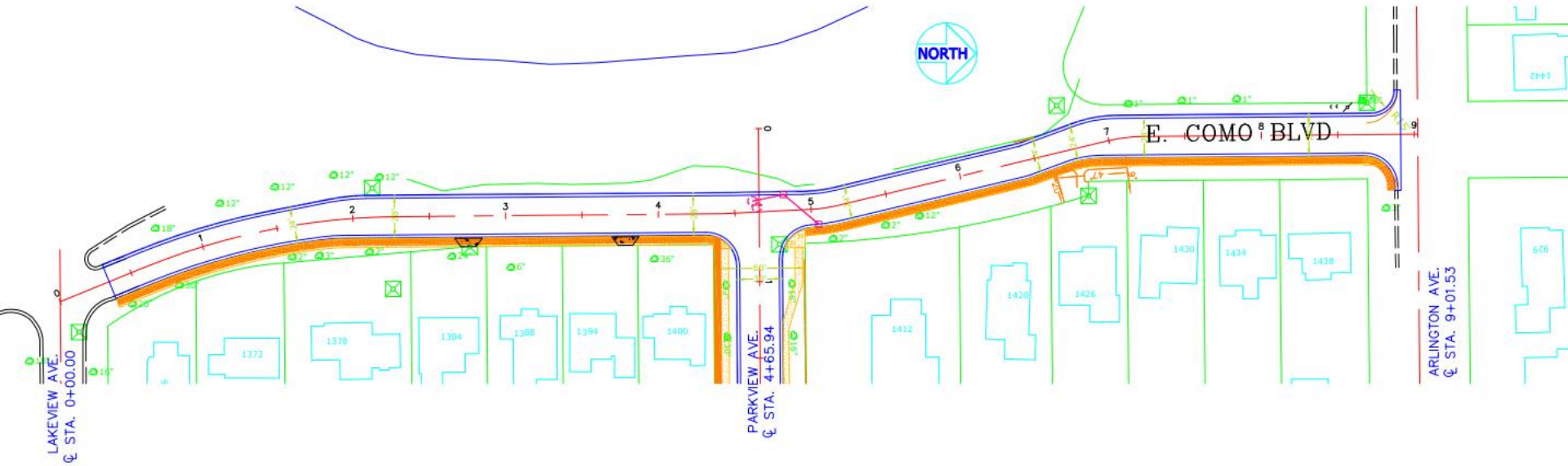



WHEELLOCK/GROTTO PHASE 1 - OSAGE ST.

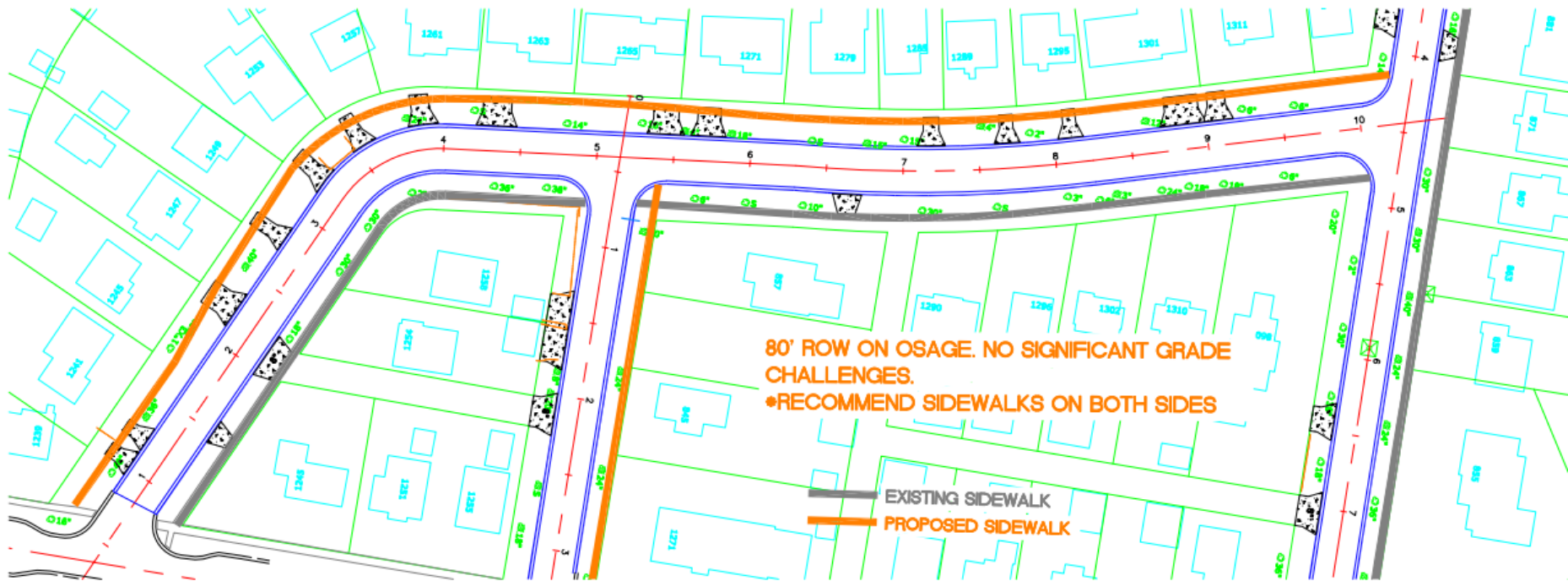



WHEELLOCK/GROTTO PHASE 1

- **Public Works Sewers sent out sanitary service replacement waivers to residents - February 4, 2025**
- **Deadline for returning waiver forms - March 31, 2025**

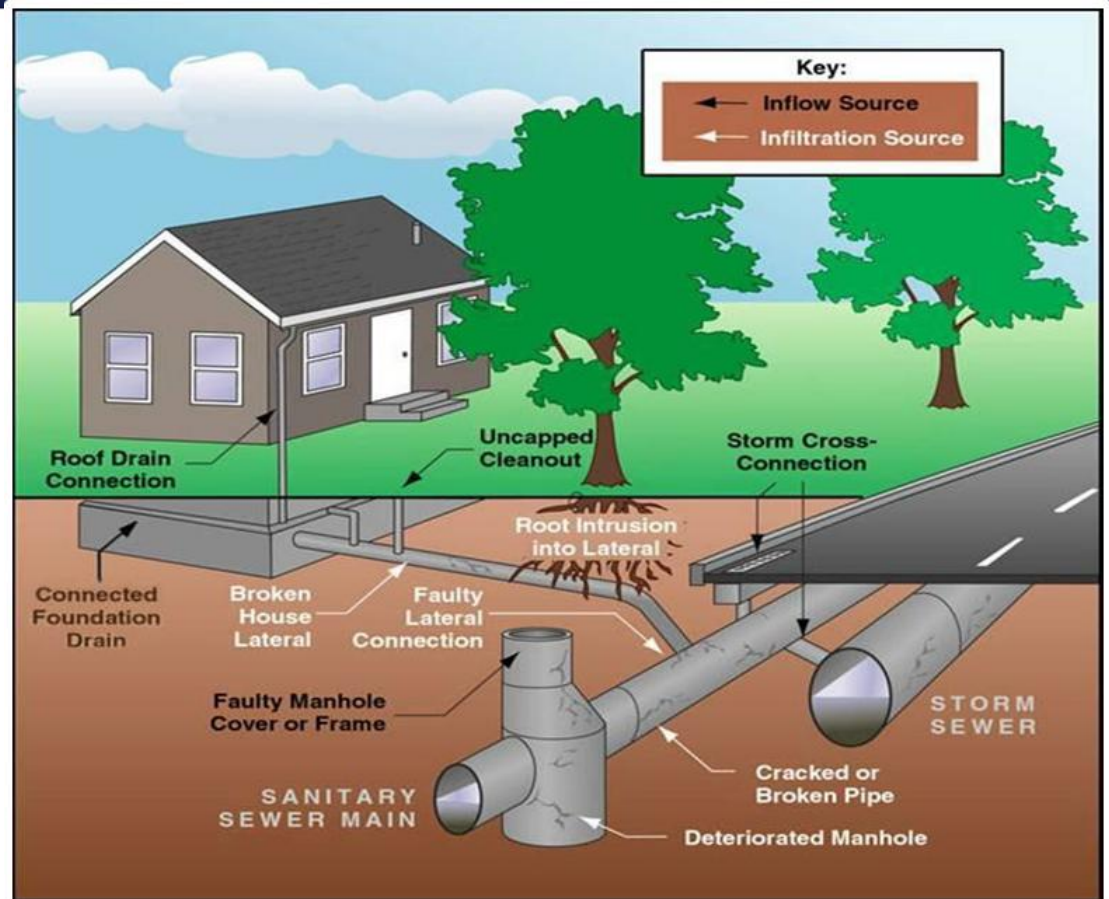



WHEELLOCK/GROTTO PHASE 1

- Submitted permit application to Watershed District for 3 underground infiltration trenches to improve water quality.

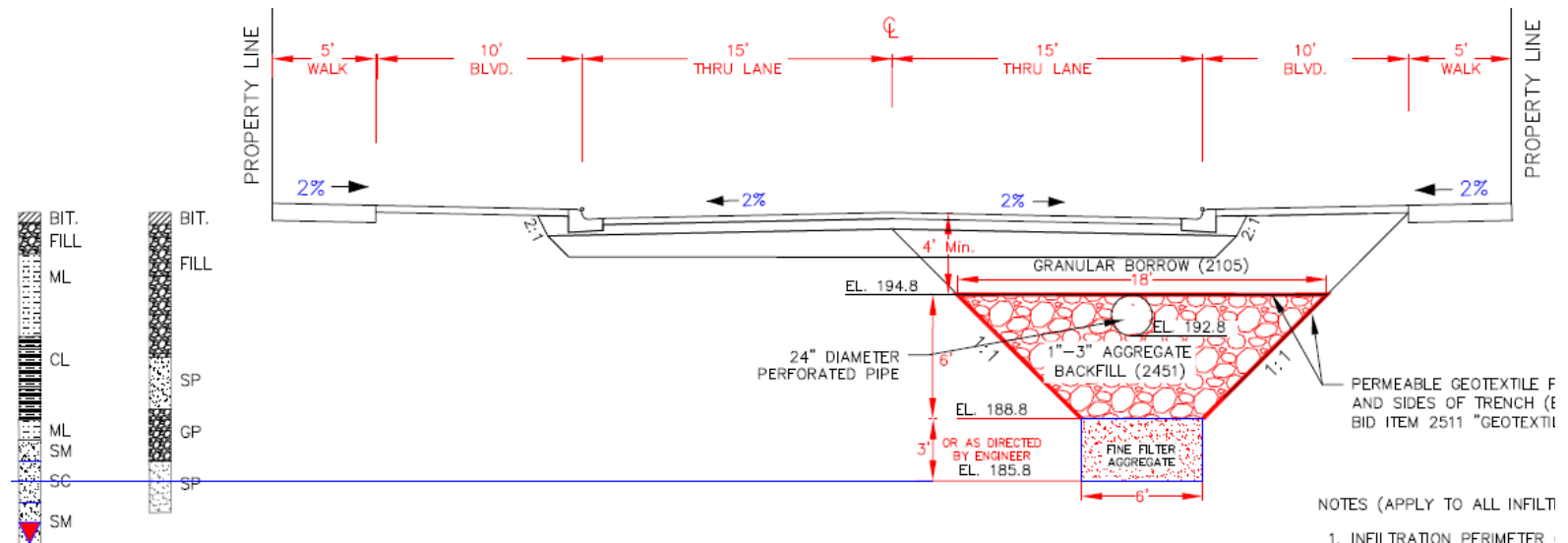

Curb Cut Boulevard Rain Garden Grants



Street reconstruction is an excellent time to add rain gardens to treat polluted street runoff.

CRWD partners with City of St. Paul to design and construct of curb cut boulevard rain gardens during road work, residents maintain the garden.

CRWD will reach out to good candidate sites based on boulevard width, road slope, and location of storm sewer inlets.

For more information:

Chris Kucek
ckucek@capitolregionwd.org
(651) 644-8888 Ext. 112

www.capitolregionwd.org

Roots channeling water

Native soil

CAPITOL REGION WATERSHED DISTRICT





WHEELOCK/GROTTO BIKE PLAN RECOMMENDATIONS

The project will implement a Bicycle Boulevard on E. Como Blvd. between Lakeview and Arlington in accordance with the approved Bicycle Plan.



<https://www.stpaul.gov/departments/public-works/transportation-and-transit/bike-saint-paul/saint-paul-bicycle-plan>



Wheelock/Grotto Communications

- **Preliminary Notice sent to residents on June 26, 2024**
- **Virtual Presentation posted on website on October 18 ,2024**
- **Virtual Open House on November 7, 2024**
- **In person Open House on November 12, 2024**
- **Sewer Waiver letters sent on February 4, 2025**
- **Sidewalk update letter sent on February 13, 2025**
- **Virtual Open House March 11, 2025**
- **Public Hearing April 23, 2025**
- **Bid Opening on April 30, 2025**
- **Construction Notice Letter prior to June, 2025**
- **Construction start June 2, 2025**