



Saint Paul Regional Water Services

Saint Paul, Minnesota

STANDARDS for the Installation of Water Mains

January 17, 2025

Summary of 2025 Revisions to the SPRWS Standards

Added text shown underlined and italicized

~~Deleted text shown in strikethrough~~

Page 6- addition to 2100 PLAN REVIEW:

If design aspects are not explicitly described in the following sections, SPRWS adheres to the 10-State Standards as administered by the Great Lakes – Upper Mississippi River Board of State and Provincial Public Health and Environmental Managers.

Page 13- additions to 2360 SERVICE CUTOFFS:

When Contractor is performing service taps on an existing water main, they shall be responsible for any associated cutoffs of existing services. This work must be completed before any new water services are activated. Rods and bands will be allowed on large service cutoffs. When cutting off a large service, the valve shall be shut and a mechanical joint plug shall be installed onto the valve. Rods and bands are allowed on large service cutoffs.

All small services to be cut off shall be capped, with the standpipe pulled. Copper services to be cutoff shall be capped with a copper disc. Corp caps shall be A.Y. McDonald Lead Corp Cap 74742LFCAP with Fiber Washer 4742LFGSKT , Ford Brass End Caps CAP2-X-NL, or approved equal. Alternatively, an AY Copper Flare Shut-Off Disc 6125 or approved equal may be used in conjunction with the existing corp nut.

Page 16- addition to 2560 ABANDONMENT OF EXISTING PIPE:

When abandoning pipe 12” and larger, pipe shall be filled with a flowable fill or approved granular material. Pipe 6” or 8” shall be likewise filled on a case-by-case basis as determined by SPRWS inspector or engineer.

Page 19- addition to 3140 PIPE FITTINGS:

Mechanical joint restraints shall be ductile iron and shall conform to the latest revision of ANSI/AWWA C111/A21.11. Restraints shall be hexagonal in shape with a full-bodied, solid, outer ring. Lightweight, compact glands and glands with ear-type retainer lugs are **not** acceptable. Mechanical joint restraints shall have a minimum rated working pressure of 250 psi. Foster Adaptors, such as those manufactured by Infact Water Utility Products, for mechanical joint restraints are acceptable.

Page 21- additions to 3210 GATE VALVES 4-INCH THROUGH 12-INCH:

Gate valves shall be resilient-seated, non-rising stem (NRS), suitable for buried service and shall conform to the latest revision of ANSI/AWWA C51509, with the following specific options:

1. Valves shall be right-hand opening (clockwise) with red wrench nut.
2. Stem seals shall be O-ring type.
3. Bolting materials shall be stainless steel with hexagonal heads and shall have the mechanical strength requirements of ASTM F593.
4. Gate valves shall have mechanical joint valve ends. Tapping valves shall have full-size cutter diameter with tapping or mechanical joint valve ends.

Page 28: addition to 3320 CURB STOP BOXES:

Curb stop boxes shall be A.Y. McDonald Mfg. Co.5632a, 5628a, or 5631a supplied with 5627L lid or approved equal. Parts from different manufacturers may be interchanged, provided they are compatible with each other. Curb stop boxes and accessories shall be coated with an asphalt-based paint. Curb stop box must be compatible with curb stop valve.

Page 23- addition to 3340 SERVICE CONNECTION SADDLES:

Service Saddles shall be Mueller DR2A, A.Y. McDonald 4825A, Ford F202, JCM 402, Smith-Blair 313, or approved equal. Service saddle bodies shall be used for service connections on 1.5-inch and 2-inch services. Saddles shall be of ductile iron or stainless steel with synthetic rubber gaskets and with threads suitable for use with standard CC (AWWA Taper Thread) Mueller corporation valves. Saddles must have a minimum of two bands, and bands shall be bronze, stainless steel, or alloy. Nuts and bolts shall be of the same material as the bands. Smith-Blair 372 Service Saddles shall not be allowed for this application.

Page 26- revisions to 3710 GALVANIC MAGNESIUM ANODE:

Anodes shall be prepackaged in a water permeable cloth ~~or paper bag~~ containing a low resistivity backfill material, consisting of 75% hydrated Gypsum, 20% bentonite and 5% sodium sulfate. A minimum of 20 feet of unspliced No. 10 AWG copper wire with ~~THHN~~THHN insulation shall be attached to the anode. Anode lead wires shall be black in color.

Page 36- addition to 4570 UTILITY OFFSETS:

Water main offsets shall be installed in accordance with **Standard Plate D-10**.

If the section AB is longer than a standard length of pipe, no slip joint will be allowed. In addition, anodes shall be installed for offsets of existing watermain. Refer to Section 3710 for magnesium anode requirements.

Page 40- revision and addition to 4760 HYDRANT CONNECTION TO MAIN:

Hydrants shall be connected to the main with a 6-inch ductile iron branch controlled by an independent 6-inch gate valve, except as otherwise directed or shown on the plans. Refer to **Standard Plate D-3**. The preferred location of the hydrant control valve is 2 feet in front of the hydrant. If hydrants are connected to 16-inch and larger water mains, the hydrant branch shall be offset down, if necessary, to produce 8 feet of cover. All hydrants constructed off of new water main shall have a bury depth of 98' feet. When working in project areas with watermain shallower than the standard depth, hydrants with shorter bury depth may be approved by SPRWS inspector or engineer.

Page 43- revision to 4930 BACKFILL PROCEDURE ABOVE THE PIPE ZONE:

Backfill shall be thoroughly compacted to the satisfaction of Municipal or Project Inspector or Engineer. For each 12" lift during the backfill process, a 3-foot radius around each valve box, hydrant and stop box shall be thoroughly compacted to ~~95% compaction~~ conforming to MnDOT standards with hand operated mechanical equipment. Puddling with water will not be permitted. In a city street, compaction shall conform to the local city standards and shall be subject to approval by said local authority.

Page 45- addition to 5310 HYDROSTATIC PRESSURE TEST- MAINS AND D.I. SERVICE CONNECTIONS:

Newly laid pipe shall be subjected to a hydrostatic pressure of 150 psi or 50% over static pressure, whichever is greater, for a period of 120 minutes. This period begins after the pressure is stabilized. Each valved section of water main shall be tested independently. Only tested and approved sections of water main may be connected to the existing distribution piping. Subjecting existing water mains, fittings or valves to full test pressures is prohibited. Pressure tests shall be performed in conformance with the latest revision of ANSI/AWWA C600. No service connection taps will be permitted until the hydrostatic pressure test and the bacteriological test have been approved. Where it is necessary to test existing mains, a pressure not exceeding 100 psi shall be established at the lowest point of elevation. No service connection taps will be permitted until the hydrostatic pressure test, the bacteriological test, and conductivity test have been approved.

Table of Contents

DIVISION 1000: DEFINITIONS.....	5
1100 BOARD OF WATER COMMISSIONERS	5
1200 CITY.....	5
1300 CONTRACTOR.....	5
1400 ENGINEER.....	5
1500 ENGINEER’S INSPECTOR	5
1600 SAINT PAUL REGIONAL WATER SERVICES (SPRWS)	5
1700 SPRWS INSPECTOR	5
1800 ADMINISTRATIVE AUTHORITY.....	5
DIVISION 2000: ENGINEERING DESIGN STANDARDS	6
2100 PLAN REVIEW	6
2200 WATER MAIN DESIGN.....	6
2210 LOCATION	6
2220 EASEMENTS	6
2230 GRADE.....	8
2240 DEPTH.....	8
2245 PIPE DEFLECTION	9
2250 JOINT RESTRAINT	9
2260 WATER MAIN VALVE LOCATIONS	9
2265 DEAD ENDS	10
2270 BLOW-OFFS	10
2280 AIR VENTS	10
2285 CATHODIC PROTECTION SYSTEMS	10
2300 WATER SERVICE CONNECTIONS	10
2310 SERVICE CONNECTIONS INSTALLED FROM EXISTING MAINS	11
2320 SERVICE CONNECTIONS INSTALLED FROM NEW MAINS	11
2330 SERVICE CONNECTION VALVE LOCATIONS	12
2340 SERVICE CONNECTION DEPTH.....	12
2350 SERVICE CONNECTION MATERIAL	13
2360 SERVICE CUTOFFS	13
2400 HYDRANTS	13
2410 LOCATION AND SPACING.....	13
2500 GENERAL.....	14
2510 CASING PIPE.....	14
2520 INSULATION.....	14
2530 UNDERMINING	15
2540 SAFETY REGULATIONS.....	15
2550 APPROVED EQUAL.....	15
2560 ABANDONMENT OF EXISTING PIPE	15
DIVISION 3000: MATERIALS.....	16

3100 PIPE AND APPURTENANCES	16
3110 DUCTILE IRON PIPE	16
3120 PLASTIC PIPE.....	17
3130 STEEL PIPE.....	17
3140 PIPE FITTINGS	17
3150 TAPPING SLEEVES	19
3160 CONDUCTIVITY	20
3170 POLYETHYLENE ENCASEMENT	21
3200 VALVES.....	21
3210 GATE VALVES 4-INCH THROUGH 12-INCH.....	21
3220 BUTTERFLY VALVES 16 INCH AND LARGER.....	21
3230 VALVE BOXES	22
3300 SERVICE AND LAWN SPRINKLER CONNECTIONS	23
3310 CURB STOP VALVES	23
3320 CURB STOP BOXES.....	23
3330 COPPER MAINS AND SERVICE PIPES.....	23
3340 SERVICE CONNECTION SADDLES.....	24
3350 SERVICE COUPLINGS	24
3360 CORPORATION VALVES.....	24
3400 FIRE HYDRANTS.....	24
3500 SALVAGED MATERIALS	25
3600 METRIC EQUIVALENTS.....	25
3700 CATHODIC PROTECTION SYSTEM.....	25
3710 GALVANIC MAGNESIUM ANODE.....	25
3720 TEST STATIONS	26
3730 JOINT BONDING.....	27
3740 ISOLATION JOINTS.....	27
3750 INSULATING FLANGE.....	27
3760 EXOTHERMIC WELDS.....	27
3770 BITUMASTIC COATING	27
DIVISION 4000: INSTALLATION OF PIPE AND APPURTENANCES	28
4100 GENERAL INFORMATION.....	28
4110 PRECONSTRUCTION REQUIREMENTS.....	28
4120 NOTIFICATION.....	29
4130 MATERIALS	29
4140 INTERRUPTION OF WATER SERVICE.....	29
4150 CORROSION CONTROL.....	30
4200 HANDLING PIPE AND ACCESSORIES.....	30
4210 CARE IN HANDLING.....	30
4220 PLACEMENT OF PIPE	30
4230 CARE OF PIPE COATING.....	30
4240 PIPE STAGING	30

4250 PIPE AND APPURTENANCE CLEANLINESS	31
4260 PIPE LINING	31
4300 ALIGNMENT AND GRADE.....	31
4310 GENERAL	31
4320 PROTECTING UNDERGROUND AND SURFACE STRUCTURES	31
4330 OBSTRUCTIONS CAUSED BY OTHER UTILITIES	31
4340 DEVIATION WITH ENGINEER’S CONSENT.....	32
4350 PIPE COVER	32
4400 EXCAVATION AND PREPARATION OF TRENCH.....	32
4410 EXCAVATION SAFETY	32
4420 WIDTH	33
4430 PIPE FOUNDATION	34
4440 PIPE FOUNDATION AND BACKFILL IN POOR SOIL	34
4450 PIPE FOUNDATION IN WET SOIL	34
4460 PIPE FOUNDATION AND BACKFILL IN ROCK	34
4500 INSTALLATION OF PIPE	34
4510 MANNER OF HANDLING PIPE AND ACCESSORIES	34
4520 PIPE INSTALLATION CLEANLINESS	35
4530 CUTTING PIPE	35
4540 PIPE INSTALLATION	35
4550 PERMISSIBLE DEFLECTIONS AT JOINTS.....	35
4560 UNSUITABLE CONDITIONS FOR LAYING PIPE	35
4570 UTILITY OFFSETS	35
4600 JOINTING PIPE.....	36
4610 PREPARATION OF PIPE.....	36
4620 ASSEMBLY OF MECHANICAL JOINT PIPE.....	37
4630 ASSEMBLY OF PUSH-ON JOINT PIPE.....	37
4640 CONDUCTANCE OF PLASTIC PIPE.....	38
4650 JOINT RESTRAINT	38
4660 CONCRETE MAIN.....	38
4700 SETTING VALVES, VALVE BOXES, SERVICE STOPS, HYDRANTS AND FITTINGS.....	39
4710 JOINTING.....	39
4720 VALVE BOXES	39
4730 SERVICE CONNECTION BOXES	39
4740 HYDRANT LOCATIONS	39
4750 HYDRANT POSITION AND ELEVATION.....	39
4760 HYDRANT CONNECTION TO MAIN	40
4770 HYDRANT SETTING	40
4780 PLUGGING DEAD ENDS.....	40
4800 CATHODIC PROTECTION INSTALLATION	40
4810 GALVANIC MAGNESIUM ANODES.....	40

4820 WIRES	41
4830 JOINT BONDING.....	41
4840 TEST STATION	41
4850 INSULATED FLANGED JOINTS.....	41
4860 EXOTHERMIC WELDS.....	41
4870 PETROLATUM WAX TAPE	42
4900 BACKFILLING AND CLEAN UP	42
4910 BACKFILL PROCEDURE AT PIPE ZONE	42
4920 BACKFILL MATERIAL EXCLUSION ABOVE THE PIPE ZONE	42
4930 BACKFILL PROCEDURE ABOVE THE PIPE ZONE.....	43
4940 CLEAN UP	43
DIVISION 5000: TESTING OF PIPE, SERVICE CONNECTIONS, AND APPURTENANCES	43
5100 FILLING AND CHLORINATION OF COMPLETED MAINS	43
5110 PROCEDURE	43
5120 CHLORINATION TO BE PERFORMED BY CONTRACTOR.....	44
5130 CONTINUOUS FEED (LIQUID) METHOD	44
5140 TABLET (GRANULAR) METHOD	44
5200 FLUSHING THE MAIN	45
5210 FLUSHING MAINS AFTER CHLORINATION.....	45
5220 DECHLORINATION.....	45
5300 PRESSURE AND HYDROSTATIC TESTS	45
5310 HYDROSTATIC PRESSURE TEST – MAINS AND D.I. SERVICE CONNECTIONS	45
5320 HYDROSTATIC PRESSURE TEST – COPPER MAINS AND SERVICE CONNECTIONS	46
5330 PROCEDURE	46
5340 EXAMINATION UNDER PRESSURE.....	46
5350 HYDROSTATIC TEST.....	46
5360 VARIATION FROM PERMISSIBLE LEAKAGE	48
5400 BACTERIOLOGICAL TESTS	48
5500 ELECTRICAL CONDUCTIVITY TEST	48
5600 CATHODIC PROTECTION SYSTEM TESTING	48
5700 INSPECTIONS	49
5800 AS-BUILT DRAWINGS.....	49

DIVISION 1000: DEFINITIONS

1100 BOARD OF WATER COMMISSIONERS

The Board of Water Commissioners of the City of Saint Paul, the governing body of Saint Paul Regional Water Services.

1200 CITY

The municipality in which the project is located.

1300 CONTRACTOR

The Contractor awarded the project.

1400 ENGINEER

The consultant Engineer or City engineering staff and/or their designated inspector assigned the engineering of the project.

1500 ENGINEER'S INSPECTOR

The inspector assigned to the project by the consultant or City engineering staff to inspect the project construction.

1600 SAINT PAUL REGIONAL WATER SERVICES (SPRWS)

The purveyor of the water supply used in the City and the utility that maintains the water distribution system of the City.

1700 SPRWS INSPECTOR

The inspector assigned by the Saint Paul Regional Water Services as its representative to inspect construction, verify materials used, and witness testing of the water main and appurtenances installed.

1800 ADMINISTRATIVE AUTHORITY

The Board of Water Commissioners of the City of Saint Paul.

- END OF DIVISION 1000 -

DIVISION 2000: ENGINEERING DESIGN STANDARDS

2100 PLAN REVIEW

Plans and specifications shall be submitted to SPRWS in hard copy and electronic format a minimum of four weeks before a contract is advertised for bids. Electronic format shall be in accordance with current industry standards in AutoCAD or ESRI GIS format (plan view only in GIS), as may be determined appropriate by SPRWS. AutoCAD drawings shall include any customized Plot Style Tables (.ctb or .stb) or line types (.lin) and shall not require links to other drawings. Any changes in approved plans must be resubmitted for review and approval. Plans must show both plan and profile views of facility to be constructed. Fittings shall be identified and located by station or other suitable dimensions. The plan should also indicate both existing and proposed utilities located within the construction area.

If design aspects are not explicitly described in the following sections, SPRWS adheres to the 10-State Standards as administered by the Great Lakes – Upper Mississippi River Board of State and Provincial Public Health and Environmental Managers

2200 WATER MAIN DESIGN

2210 LOCATION

Water mains shall be designed for installation in the standard water main location in a public street for which a permanent grade has been established, on the north or west side of the street at approximately one third the full street right-of-way width (not less than 15 feet) from the property line. Refer to **Standard Plate D-1**. Public mains shall be installed in paved areas whenever possible. If a conflict exists at that location, the main shall be designed to provide the following minimum clearances: 10 feet from sanitary sewer, 5 feet from storm sewer and any other underground structure or utility. Additionally, water mains shall be designed to maintain a minimum horizontal clearance of 10 feet from trees. Trees installed after the placement of the water main shall be planted with at least 10 feet of horizontal clearance.

2220 EASEMENTS

Also see PRIVATE WATER MAIN SUPPLEMENT, page PM-1

The installation of public mains in easements will be considered only if the main represents a significant improvement to the distribution system that cannot be achieved by using public streets. Public mains in easements shall be installed in paved areas whenever possible.

A public water main may be installed in an easement within private property only if approved in advanced by SPRWS and shall be subject to the following requirements:

1. The easement area shall be 30 feet wide with the water main centered in the easement. Easements of greater width may be accepted with prior SPRWS approval. The easement shall be shown on the recorded plat for the area being developed or a dedicated easement shall be on file in the records of the County Recorder.

2. If a water main and a sanitary or storm sewer are in the same easement, the water main shall be a minimum of 15 feet from either side of the easement with a minimum 10-foot horizontal separation between sanitary sewer and water main and a minimum 5-foot horizontal separation between storm sewer and water main.
3. The easement shall be subject to the following conditions:
 - a. No change from the existing grade shown on the approved plans is permitted within the easement area after the water main is in place. Plans submitted must include the existing and proposed topography within and adjacent to the proposed easement.
 - b. Buildings, structures, material piles, trees, fences, etc. which may prevent access to the water main by SPRWS are not permitted within the easement area.
 - c. Should it be necessary that improvements or works be removed or damaged as a result of SPRWS operations, the costs of removal, replacement or modification of said works or improvements shall be borne solely by the owner.
 - d. No change of the existing surface within the easement area is permitted without SPRWS approval.
 - e. When SPRWS performs maintenance work in an easement area, surface restoration of pavement, sidewalks, shrubbery, grass, trees, etc., must be by others at no expense to SPRWS.
 - f. Additional utilities may be installed in the easement subject to SPRWS prior approval and must be constructed in accordance with separation requirements described in **Section 2210**.
4. If a service connection is to be extended beyond the normal street right-of-way line by SPRWS, a construction easement must be provided for that purpose. SPRWS will maintain only that portion of the service connection in the street right-of-way.
5. The grade throughout an easement area and the side slope shall not exceed a four to one (4:1) slope.

Where a water main easement is not in a paved area, **Standard Plate D-12** and the following shall apply:

- a. The centerline of all easements shall be identified by placing markers at either end of the easement and at 250 foot intervals or less throughout. Two (2) markers must be visible at all times from any point within the easement area. Markers shall also be placed at angle points when the easement diverges from a straight line.

- b. Markers shall have 360 degrees of visibility and shall be Rhino TriView posts with TriGrip Anchoring system, or approved equal. Markers shall be composed of a durable material which can perform in temperatures between -40° to +150°F, remain UV stable for 10 years, have a blue post with a black cap fastened to the top, and buried a minimum of 24-inches below the finished grade. A SPRWS Warning decal shall be adhered to each side of the marker; Rhino part number SD-6449K.
- c. At SPRWS sole discretion, alternate means of marking easement centerlines may be considered.

2230 GRADE

The grade used to determine water main depth shall be as determined by Engineer and as shown on the construction plan. Water mains shall not be installed in ditches or other locations where there is not a street grade. However, if it is necessary to install a water main where there is not an established permanent street grade, or where the main is installed in an easement, a profile shall be taken on top of the water main during construction and on the finished ground line above the main after final grading has been completed to determine if the main is at the correct depth. The profiles shall be taken by Engineer or its representative. A copy of these profiles must be on file with SPRWS before the main is accepted for maintenance by SPRWS.

No reduction in earth cover is allowed over any main or service connection which has a previous history of freezing, unless the main or service connection is adjusted to proper depth under new finished grade as specified in **Section 2240**.

If the grade over an in-place water main or service connection 8-inch and smaller is changed to produce an earth cover of less than 7 feet or greater than 9.5 feet, the main or service connection must be adjusted to the proper depth as specified in **Section 2240**. Grade changes over in-place 12-inch and larger water mains and service connections shall be evaluated by SPRWS and shall be adjusted to proper depth if required.

2240 DEPTH

Depth of cover over the top of pipe shall be as follows:

<u>Pipe Size</u>	<u>Depth</u>
less than 12"	8.0 feet
12"	7.5 feet
16"	7.0 feet
20"	6.0 feet
24"	5.5 feet
30"	5.0 feet
36"	4.5 feet

Variations may be considered and approved by SPRWS. If service connections are anticipated to be installed on large diameter mains, the depth of water main cover shall be determined by SPRWS. Four (4)-inch through 16-inch pipe may be installed with 6.5 feet of cover where solid rock trench conditions are encountered. Protective measures to prevent freezing may be required depending upon conditions encountered.

2245 PIPE DEFLECTION

Water main design may provide for joint deflection of ductile iron pipe to produce a uniform alignment around a curve only where the curve radius is greater than 400 feet for 12-inch and smaller pipe and greater than 600 feet for 16-inch through 24-inch pipe. The design of water mains around curves of smaller radii must provide for bends to produce the required deflection.

2250 JOINT RESTRAINT

Joint restraint shall be accomplished by means of mechanical pipe jointing; such as mechanical joint pipe, mechanical joint wedge restraints, or other approved methods.

Restrained joint gaskets comprised of embedded stainless steel locking elements are permitted for use in restraining slip joint ductile iron pipe for pipe sizes up to and including 24". Restrained joint gaskets may not be used for pipe larger than 24" in diameter. Restrained joint gaskets shall be American Fastite joint type with Amarillo Fast-Grip, U.S. Pipe Tyton joint type with Barracuda, or pre-bid approved high visibility equal. The high visibility color shall be consistent throughout the entire cross section of the gasket.

Restraining gaskets shall be manufactured in the United States. Gaskets shall meet all applicable requirements of AWWA/ANSI C111/A21.11, latest revision. Gaskets shall be styrene butadiene rubber (SBR), and shall be NSF Standard 61 certified for contact with potable water. Pressure ratings for restraining gaskets shall be 350 psi for 4" through 18", 250 psi for 20" through 24", but in no case shall the joint be considered rated at a higher pressure than the pipe of which it is a part.

Rods and bands are **not** permitted. Where mechanical joint restraint or other joint restraint is not possible, and with prior approval of SPRWS Inspector, poured concrete may be used as reaction backing at fittings. Reaction backing shall be of sufficient size to absorb all of the thrust created by maximum internal water pressures. If joint restraint is used for absorbing a portion of the thrust, the reaction backing shall be adequate to absorb all remaining thrust. The reaction backing shall be placed against undisturbed soil and the fittings are to be anchored. The fitting joints must be accessible for repair. Reaction backing must be designed by a licensed engineer and approved by SPRWS Inspector. Reaction backing is **not** allowed on hydrant installations.

2260 WATER MAIN VALVE LOCATIONS

Valves shall be located at intersections on the projected property line of the intersecting street. An adequate number of valves shall be used such that no more than two blocks of main on any one residential street would be shut down at any one time. It is recommended

that valves be installed at every intersection. On long continuous sections of main, valves shall be located at least every 1,000 feet. Sixteen (16)-inch and larger valves shall be butterfly valves. Twelve (12)-inch and smaller valves shall be gate valves. Valves shall be installed on all hydrant branches, except in locations where the hydrant can be isolated using main valves in the immediate vicinity.

2265 DEAD ENDS

Dead end mains should be avoided by looping all mains. Dead end mains shall be allowed only with SPRWS prior approval. Where dead end mains are approved, a fire hydrant or approved blow-off shall be installed on the end of the main for flushing purposes. No flushing device shall be directly connected to any sewer.

2270 BLOW-OFFS

Two (2)-inch blow-offs shall be installed at low points on 6-inch and 8-inch mains. Four (4)-inch blow-offs shall be installed at low points on 12-inch and 16-inch mains and 6-inch blow-offs on mains larger than 16-inches. The use of hydrants as blow-offs is permitted. SPRWS shall make the determination where blow-offs are required. Blow-offs shall be constructed near the main so they can be drained to the street by pumping. Draining the blow-off to “open-air” is an acceptable alternate to draining the blow-off to a manhole. Refer to **Standard Plates D-8** and **D-9**.

2280 AIR VENTS

Air vents or hydrants shall be installed at high points on each valved section of main. SPRWS shall make the determination where air vents are required. Air vents that have less than 7 feet of cover shall be insulated from the corporation valve to the curb stop valve. Refer to **Standard Plate D-7** for installation details.

2285 CATHODIC PROTECTION SYSTEMS

The level of cathodic protection required on a water main will be determined by SPRWS. Soil boring reports and soil resistivity testing will aid in the determination of appropriate system requirements, such will be indicated on project plans.

2300 WATER SERVICE CONNECTIONS

Water service connections shall be designed and installed in accordance with **Standard Plate D-13**. Water service connection taps shall be performed by Contractor for services coming off existing iron water main that is 12-inch and smaller and on new mains installed by Contractor. Any taps on non-iron water main and on iron water main sized larger than 12-inch will be performed by SPRWS. New mains may be tapped by Contractor in accordance with **Section 2320**.

Wherever possible, service connections shall be located at the center of residential lots and shall not be located within driveways nor within 10 feet of trees, culverts, catch basins, utility poles or other obstructions.

Tapping saddles are required for 1-inch services tapped on cast iron pipe. Tapping saddles are **not** permitted for 1-inch services tapped on ductile iron pipe.

All maintenance, repair or reconstruction of existing water services shall be performed by SPRWS.

Services shall be installed to ROW line.

2310 SERVICE CONNECTIONS INSTALLED FROM EXISTING MAINS

Service connections installed from existing mains shall be installed 10 feet from sanitary sewer services.

In Street Right of Way

Excavation for service connection piping in public street right-of-way shall be performed by Contractor, unless otherwise approved in advance by SPRWS.

In Easements

Service connection piping in easements may be installed by Contractor with the tap performed by SPRWS. However, 2-inch and smaller water service connection piping in public easements owned by the City may be installed by SPRWS, if requested by the City.

2320 SERVICE CONNECTIONS INSTALLED FROM NEW MAINS

Service connection piping from new mains may be installed by Contractor, if so desired by the host City or SPRWS, as prescribed below.

Excavation for service connection piping from new mains shall be performed by the excavator of the new main.

Water services shall be installed and tested independent of the water main and in accordance with **Section 5320**.

Water Service in Common Trench with Sanitary Sewer Service

Service connection piping from new mains in public street rights-of-way or easements may be installed in the same trench as the sewer service subject to requirements of Minnesota Administrative Rules (MAR) 4715.1710 and the following:

1. Water services shall be located a minimum of 3 feet laterally from the sewer service.
2. The bottom of the water service pipe at all points shall be at least 12-inches above the top of the sewer service line at its highest point. Where this condition cannot be met, the sewer pipe material shall be ductile iron or D.R. 18 PVC.
3. Water service pipes shall be installed on a solid shelf of undisturbed soil excavated at one side of the common trench. The water service pipe shall be of one piece. Where

this is not feasible, the number of joints in the service pipe shall be kept to a minimum and the joints shall be brazed.

4. Sewer service pipes shall be tested as described in MAR 4715.2820 or by methods acceptable to the Administrative Authority.

Water Service in Separate Trench from Sanitary Sewer Service

Service connection piping from new mains in public street rights-of-way or easements may be installed in a trench separate from the sewer service subject to the conditions below.

1. Service connection piping may be installed by Contractor only if installed and tested in conjunction with the new main.
2. Service connections shall be located a minimum of 10 feet from the sewer service.
3. Service connections installed by SPRWS from new main installed by Contractor will not be installed until the main has been pressure tested and approved by SPRWS Inspector.

2330 SERVICE CONNECTION VALVE LOCATIONS

General

1. Unless approved in advance by SPRWS, service valve boxes shall not be located in a sidewalk, driveway or ditch section.
2. Service valve boxes shall be set flush with the finished ground elevation.

Service Connection Valves in Street Right-of-Way

Generally, 4-inch and larger service valves shall be placed 2 feet from the water main. Two (2)-inch and smaller curb stop valves shall be placed 7 feet out from right-of-way line. Service connection shall be extended to right-of-way line or through utility easement.

Service Connection Valves in Easements

Valves on 4-inch and larger services shall be placed 2 feet from the water main. Valves on 2-inch and smaller services shall be placed within 4 feet of the water main. If the easement is paved, the valve may be located in accordance with the requirements for service connection valves in street right-of-way.

2340 SERVICE CONNECTION DEPTH

Service connections shall be installed with 8 feet of cover as per the established grade from the main to the property line or, if applicable, to the utility easement line. When solid rock conditions are encountered, water services may be installed with 6.5 feet of cover. At this depth, the need for insulation will be determined by SPRWS Inspector. Existing service replacement depths will be reviewed on a case-by-case basis.

2350 SERVICE CONNECTION MATERIAL

Two (2)-inch and smaller service connections shall be copper pipe. Four (4)-inch and larger service connections shall be ductile iron pipe. Refer to **Section 3100**.

2360 SERVICE CUTOFFS

When Contractor is performing service taps on an existing water main, they shall be responsible for any associated cutoffs of existing services. This work must be completed before any new water services are activated. Rods and bands will be allowed on large service cutoffs. When cutting off a large service, the valve shall be shut and a mechanical joint plug shall be installed onto the valve. Rods and bands are allowed on large service cutoffs.

All small services to be cut off shall be capped, with the standpipe pulled. Copper services to be cutoff shall be capped with a copper disc. ~~If service cutoff is performed on a lead service line and the corporation valve is leaking after the cutoff, a corp cap will be used on the leak.~~ Corp caps shall be A.Y. McDonald Lead Corp Cap 74742LFCAP with Fiber Washer 4742LFGSKT , Ford Brass End Caps CAP2-X-NL, or approved equal. Alternatively, an AY Copper Flare Shut-Off Disc 6125 or approved equal may be used in conjunction with the existing corp nut.

2400 HYDRANTS

Approved hydrants are Waterous Company WB67 Pacer and Mueller Company Super Centurian 200. Refer to **Section 3400**.

2410 LOCATION AND SPACING

Hydrants shall be located at each street intersection. The spacing between hydrants shall not be less than 300 feet or more than 600 feet unless approved by SPRWS. Hydrants not at an intersection shall be located at a property line (lot line) which is perpendicular to the street right-of-way. Hydrants shall be a minimum of 4 feet behind the curb but not closer than 7 feet to the street right-of-way line. Hydrant shall be minimum 6 feet from any crosswalk or pedestrian ramp. Hydrants shall be placed on same side of the street as the main and only in areas which are adjacent to and directly accessible from paved roads, parking lots or driveways. Guard posts shall be required for hydrant protection in hazardous traffic areas as determined by Engineer or SPRWS Inspector. Refer to **Standard Plate D-3** for design details.

Hydrants shall be installed adjacent to a traveled roadway or parking lot as required for adequate fire protection. Hydrant spacing and location shall be reviewed by Engineer with the local City Fire Marshal.

2500 GENERAL

2510 CASING PIPE

Casing pipe (or carrier pipe) shall be used as required when crossing under railroads, light rail or state and county highways. Casing shall also be used when crossing under any obstruction which may cause future water main maintenance problems. The casing shall meet all requirements of the agency granting the crossing permit. Refer to **Standard Plate D-6** for additional requirements.

Where a casing pipe is required, further information as to the size, thickness, coatings, cathodic protection, and the saddles required is available from SPRWS. These requirements vary depending on the type, size and depth of pipe, and the particular facility being crossed. Details for the installation must be submitted to SPRWS for approval prior to construction.

2520 INSULATION

The design and use of insulation must be submitted to SPRWS for approval prior to construction. Insulation shall have a minimum compressive strength of 40 psi and shall be Dow Styrofoam HI brand plastic foam or approved equal. Insulation shall be a minimum of 4-inches in thickness. A uniform bedding material of sand shall be used around the insulation to provide uniform loading on the insulation. If SPRWS Inspector determines the bedding procedures are not adequate to properly support sheet insulation, an additional treated wood shell will be required. Any open-cell or preformed insulation shall be sealed and waterproofed by the application of a cold-applied, self-adhering, butyl-rubber protective material equal to Servi-Wrap P-400 as manufactured by the Grace Company or approved equal. Dow HI40 or HI60 plastic foam and any other approved high-density, closed-cell, plastic-shell insulation shall not be sealed when furnished in sheet form.

The following procedures and requirements shall be used as minimum guidelines for placement of insulation:

1. Where a water service or main passes within 3 feet above or below a storm sewer, insulation shall be placed between the water pipe and the storm pipe.
2. Where a water service or main is offset over a storm sewer, insulation shall be placed both over the top of the water pipe and between the water pipe and the storm sewer. Refer to **Standard Plate D-10**.
3. Where a water main or service is within 6 feet of a catch basin, manhole or other outlet that is subject to cold, insulation shall be placed between the structure and the water pipe.

Insulation shall be placed parallel to the water pipe and 2 feet beyond either side of the water pipe and shall also extend 2 feet beyond either side of the storm sewer for situations 1 and 2 above. For situation 3 above, the insulation shall extend 2 feet beyond either side of the water pipe and 2 feet beyond either side of the structure.

Greater insulation thickness and/or greater extension of insulation limits may be required by SPRWS after evaluation of the following factors: depth of cover if below ground, size of water pipe and frost generating structure, angle at which storm sewer crosses water pipe, minimum flow expected in the water pipe, insulating value of the material and effects of moisture. Further information on the design or material for insulation can be obtained from SPRWS. Insulation will not be permitted to augment cover on static water lines.

2530 UNDERMINING

Where utility work causes in-place cast iron water pipe to be undermined, the following requirements shall apply:

8-inch and smaller

Replace cast iron pipe with ductile iron pipe the width of the trench plus 2 feet on both sides of the trench.

12-inch

Replace cast iron pipe with ductile iron pipe when more than 5 feet of pipe is undermined.

16-inch and larger

Action required will be determined by SPRWS on a case-by-case basis.

If the undermining conditions do not require replacement of the undermined water pipe, Contractor shall provide suspension support of the water pipe until its entire length is supported by properly compacted soils.

2540 SAFETY REGULATIONS

Safety laws and regulations governing construction in the project shall be followed, including but not limited to, OSHA Standards for excavations, trenching and shoring (Federal Register Part 1926, Subpart P). Refer to **Section 4410** for excavation safety requirements.

2550 APPROVED EQUAL

Material specifications must be submitted to SPRWS Engineering Division for review and approval on any material requested to be substituted as approved equal.

2560 ABANDONMENT OF EXISTING PIPE

Pipe can only be abandoned with the approval of SPRWS. All abandoned pipe must be capped or bulk-headed and traceable or marked via burned RFID marker ball. Tracer wire connection materials and methods (Sections 3160 and 4640) are subject to prior approval by SPRWS Inspector. All connections shall be coated with a urethane coating (e.g. CRC Seal Coat No. 18410) or approved equal. When abandoning pipe 12" and larger, pipe shall be filled with a flowable fill or approved granular material. Pipe 6" or 8" shall be likewise filled on a case-by-case basis filled with suitable material as determined by SPRWS inspector or engineer.

DIVISION 3000: MATERIALS

3100 PIPE AND APPURTENANCES

3110 DUCTILE IRON PIPE

Pipe shall be manufactured in accordance with the latest revision of ANSI/AWWA Standard C151/A21.51 and in compliance with the latest revision of ANSI/AWWA Standard C150/A21.50. Pipe shall be SMaRT© certified by the Institute for Market Transformation to Sustainability.

All ductile iron pipe shall be manufactured in the United States. The material supplier and/or contractor shall furnish data certified by the manufacturer that all pipe is of domestic manufacture.

Ductile iron pipe used in the work shall be equal in quality to that manufactured by the United States Pipe and Foundry Company, the American Cast Iron Pipe Company, James B. Clow and Sons or approved equal. Approval does not relieve compliance with the technical and quality standards, requirements and certifications outlined herein.

The minimum allowable pipe wall thickness shall be as follows:

Size	Thickness Class	Wall Thickness
4"	53	0.32"
6"	53	0.34"
8"	52	0.33"
12"	52	0.37"
Larger	52	Varies Per ANSI/AWWA C150

Lining

Ductile iron pipe for water service shall be cement-mortar lined and shall conform to the latest revision of ANSI/AWWA C104/A21.4. The cement mortar lining shall be applied to the pipe without asphalt seal coat. Ductile iron pipe with an asphalt seal coat applied to the interior will **not** be permitted.

Coating

The exterior of ductile iron pipe shall be coated with a layer of arc-sprayed zinc per ISO 8179. The mass of the zinc applied shall be 200g/m2 of pipe surface area. A finishing layer topcoat shall be applied to the zinc. The coating system shall conform in every respect to ISO 8179-1

“Ductile iron pipes – External zinc-based coating – Part 1: Metallic zinc with finish layer. Second edition 2004-06-01. The finishing topcoat shall be NSF 61 certified for contact with potable water.

Length

All pipe shall be delivered in 18-foot or 20-foot nominal lengths.

Gauge Pipe

All pipe 12” diameter and smaller shall be supplied gauged full length. All pipe 16” diameter and larger, the contractor and/or supplier shall provide the appropriate number of gauged pipe to accommodate field cuts and joint make-up with fittings, valves, etc. Gauged pipe 16” and larger shall be marked as gauged full length with a color band painted around the circumference of the pipe within 2 feet of the bell. A gauged pipe is defined as pipe that meets circumferential tolerances as outlined in ANSI/AWWA C151/A21.51 along the entire barrel of the pipe from spigot end to within 2 feet of the bell. Any pipe not meeting requirements for gauge full length and/or other requirements of this specification will not be accepted. Within ten days from notification, the contractor/supplier will be required to remove the nonconforming pipe and deliver a replacement pipe at no cost to SPRWS.

3120 PLASTIC PIPE

Plastic pipe shall be used only with SPRWS prior approval.

Molecularly Oriented Polyvinyl Chloride (PVC0)

PVC0 pipe shall be pressure class 200 and conform to the latest revision of ANSI/AWWA. PVC0 pipe shall be C909 for sizes 4-inch through 12-inch and C905 for sizes 16-inch through 24-inch. PVC0 pipe larger than 24-inch will not be allowed. Only iron fittings are allowed.

High Density Polyethylene (HDPE)

HDPE pipe shall be pressure class 200, PE 4710, SDR-11, with ductile iron pipe sizes (DIPS) and shall conform to the latest revisions of ANSI/AWWA C906, ASTM F714 and NSF 61. Only sizes 2-inch through 24-inch are allowed.

3130 STEEL PIPE

The use of cement mortar-lined steel water pipe may be permitted in special cases such as on bridges where weight is a factor. Steel pipe shall conform to the latest revision of AWWA C200. Cement mortar lining for steel pipe shall conform to the latest revision of AWWA C205. Certain uses of steel water pipe may require special exterior coatings or cathodic protection. Additional information concerning acceptable uses for steel water pipe is available from SPRWS Engineering Division.

3140 PIPE FITTINGS

Cor-Blue corrosion-resistant, high-strength, low-alloy steel tee head bolts and nuts shall be furnished and installed on mechanical joint fittings according to the latest revision of ANSI/AWWA C111/A21.11. Bolts shall feature a baked on ceramic filled fluorocarbon resin.

Fittings for Ductile or Cast Iron Pipe

For fittings 4-inches to 24-inches, compact ductile iron fittings with a minimum working pressure of 350 psi and conforming to the latest revision of AWWA Standard C153 may be installed.

For fittings above 24-inches, mechanical joint fittings shall be used with both mechanical joint and pushon joint pipe and shall conform to the latest revision of AWWA C110. Fittings and sleeves, regardless of size, shall have a minimum rated working pressure of 250 psi.

All ductile iron tees and crosses shall be coated with zinc or fusion-bonded epoxy in accordance with AWWA C116.

Fittings manufactured by U.S. Pipe, American D.I. Pipe, Tyler Union, and Star are acceptable. Those proposing to furnish equal quality fittings must first obtain written approval from SPRWS. Fittings and Accessories must be made in the USA.

Mechanical joint restraints shall be ductile iron and shall conform to the latest revision of ANSI/AWWA C111/A21.11. Restraints shall be hexagonal in shape with a full-bodied, solid, outer ring. Lightweight, compact glands and glands with ear-type retainer lugs are **not** acceptable. Mechanical joint restraints shall have a minimum rated working pressure of 250 psi. *Foster Adaptors, such as those manufactured by Infact Water Utility Products, for mechanical joint restraints are acceptable.*

Set screws for retainer glands shall be corrosion-resistant high-strength low-alloy steel or approved equal. Series 1100 MEGALUG as manufactured by EBBA Iron, Inc., Series 3000 Stargrip as manufactured by Star Pipe Products, Series 1000 TUFgrip as manufactured by Tyler Union, or approved equal will be considered acceptable for use on ductile iron pipe. Series 110000X Oversize MEGALUG as manufactured by EBAA Iron, Inc., Series 3000OS Oversized Stargrip as manufactured by Star Pipe Products or approved equal will be considered acceptable for use on cast or grey iron pipe.

Fittings for Plastic Pipe

Fittings for PVC pressure systems shall be epoxy-coated ductile iron and shall conform to the latest revision of ANSI/AWWA C110/A21.10-12.

Mechanical joint restraints shall be used to transition from the plastic pipe to the fittings. Series 2000PV mechanical restraints as manufactured by EBAA Iron, Inc., Series 4000 PVC Stargrip as manufactured by Star Pipe Products, Series 2000 TUFgrip as manufactured by Tyler Union, or approved equal, will be considered acceptable for use on PVC plastic pipe. At locations where bends are required pre-cast thrust blocks shall be installed.

Fittings for HDPE pressure systems may be fusible HDPE material or ductile iron. No electrofusion couplings will be allowed. All fused connections shall be made via butt fusion. Mechanical joint connections on HDPE pipe or fittings shall include a stainless-steel wedge style stiffener within the connecting end.

The Romac ALPHA™ restrained joint coupling, Hymax Grip coupling, or approved equal is permitted for use on ductile iron, oversized cast iron, C909 PVC, and SDR-11 HDPE pipe. When used to couple iron pipe to iron pipe, copper straps or cable bonding shall be used to obtain conductivity between pipe sections.

3150 TAPPING SLEEVES

Tapping sleeves shall be used when tapping services larger than 2-inch on cast iron and ductile iron water main and when tapping any services on PVCO water main. Tapping sleeves shall be stainless steel with stainless steel flanges. Sleeves shall be JCM model 432, Ford Fast, or approved equal. Sleeves shall be adaptable to properly fit and seal class A, B, C and D pit cast iron, ductile iron and PVCO pipe in the following Outside Diameter sizes:

Nominal Pipe Size	Required Outside Diameter Range
4"	4.80" – 5.00"
6"	6.90" – 7.10"
8"	9.05" – 9.30"
12"	13.20" – 13.50"
16"	17.40" – 17.80"
20"	21.60" – 22.06"
24"	25.80" – 26.32"
30"	31.74" – 32.74"
36"	37.96" – 39.16"

Tapping sleeve gaskets shall provide sealing across the full pipe circumference and the full area of the sleeve. Bolts and nuts shall be stainless steel.

Taps larger than 2 inches on iron pipes require the use of a tapping sleeve, and 1.5 and 2 inch taps require a tapping saddle. All taps on plastic pipe require the use of a tapping sleeve. When tapping cast iron main, the valve and/or fittings will be sufficiently supported with concrete blocks. Before tapping the main, the sleeve will be subjected to a hydrostatic pressure of 150psi or 50% over static pressure, whichever is greater, for a 10-minute period. No loss of pressure will be permitted.

For 16-inch and larger mains, fusion-bonded, epoxy-coated, fabricated steel sleeves are permitted. Such sleeves shall be complete with stainless steel or high-strength low-alloy bolts and hexagonal nuts and a broad cross-section ring gasket. Alternate sleeves shall be JCM model 412, Ford style FTSC or approved equal.

Service connection fittings for HDPE pressure systems shall be HDPE side fusion tapping saddles with a minimum working pressure rating of 200 psi. Service saddles shall be self-

tapping and sealing. Double-strapped ductile iron body service saddles may NOT be used in lieu of side fusion saddles.

3160 CONDUCTIVITY

Ductile Iron

Joints shall be provided with an electrical bond capable of carrying 600 amps for an extended period of time to provide integral electrical thawing capability and a continuous circuit for tracing capabilities.

Mechanical joints shall have rubber gaskets conforming to the latest revision of ANSI/AWWA C111/A21.11.

Copper straps or cable bonding shall be used to obtain conductivity. If mechanical joint retainer glands are used, copper straps are optional. Push on joints shall be jumpered with copper straps, either factory or field welded. All coating, rust or foreign material must be removed prior to assembly to permit proper electrical contact. The use of wedges or gaskets with embedded copper clips is **not** permitted.

Tracer Wire for Trenchless Applications

Tracer wire used in trenchless applications shall be 7 x 7 Stranded Copper Clad Steel having a 30 volt maximum rating, a 4,700 lb break load, and HDPE wire coating with a thickness of 0.050". Wire to be Copperhead Soloshot Xtreme Strength 7x7 stranded PBX-50 or approved equal.

Tracer Wire for Direct Bury Applications

For direct bury applications with plastic pipe, tracer wire shall be No. 12 AWG, direct burial copper XLP wire or copper clad steel with 30 mil HDPE insulation and min. 450 lb. break load. Copperhead #12 High Strength 1030B-HS, Copperhead #12 Superflex 1030B-SF or approved equal.

Direct bury wire connections shall include 3-way lockable connectors and mainline to lateral lug connectors specifically manufactured for use in underground trace wire installation. Connectors shall be dielectric silicon filled and shall be installed in a manner to minimize uninsulated wire exposure. Brundy type KS15, DryConn 3-way Direct Bury Lug #3WB-01, or approved equal.

Trace Wire Termination Points

All tracer wire termination points must utilize an approved tracer wire access box or shall terminate inside gate box with approval from SPRWS inspector. A minimum of 2 feet of excess/slack wire is required in all access boxes after meeting final grade.

The box for in-ground tracer wire termination shall be an H20 rated utility box, Bingham & Taylor P525 or approved equal. The box covers for in-ground tracer wire termination boxes shall be cast iron with the legend "WATER".

Tracer wire termination boxes for hydrants shall be Copperhead T3 Test station T3-75-F, or approved equal. The mounting bracket shall be a 14 gauge, stainless steel properly affixed to the hydrant grade flange (affixing with tape or plastic ties shall not be acceptable).

3170 POLYETHYLENE ENCASEMENT

Polyethylene encasement shall be by the tube method and shall conform to the latest revision of ANSI/AWWA C105/A21.5. All polyethylene encasements shall be enhanced V-Bio film and fitted appropriately for the size of the main.

Polyethylene encasement shall be taped and secured along length of pipe and at each joint. All joints and fittings, including retainers, shall be wrapped. V-Bio shall be installed utilizing Modified Method A as recommended by DIPRA. Encasement shall be taped at each joint and around the middle of the pipe.

Polyethylene encasement for use with ductile iron pipe systems shall consist of three layers of co-extruded linear low density polyethylene (LLDPE), fused into a single thickness of not less than 8 mils.

The inside surface of the polyethylene wrap to be in contact with the pipe exterior shall be infused with a blend of antimicrobial biocide to mitigate microbiologically influenced corrosion and a volatile corrosion inhibitor to control galvanic corrosion.

3200 VALVES

3210 GATE VALVES 4-INCH THROUGH 12-INCH

Gate valves shall be resilient-seated, non-rising stem (NRS), suitable for buried service and shall conform to the latest revision of ANSI/AWWA C51509, with the following specific options:

5. Valves shall be right-hand opening (clockwise) with red wrench nut.
6. Stem seals shall be O-ring type.
7. Bolting materials shall be stainless steel with hexagonal heads and shall have the mechanical strength requirements of ASTM ~~F593A307~~.
8. Gate valves shall have mechanical joint valve ends. Tapping valves shall have full-size cutter diameter with tapping or mechanical joint valve ends.

3220 BUTTERFLY VALVES 16 INCH AND LARGER

Butterfly valves shall be mechanical joint end valves, ASTM A-126 Class B, rubber-seated, suitable for buried service, and shall conform to the latest revision of ANSI/AWWA C504. Valves shall be manufactured by Henry Pratt, Mueller or approved equal. Butterfly valves shall meet the following additional requirements:

1. Valves shall be right-hand opening (clockwise) with red wrench nut, installed facing vertically upward for key operation.
2. Valve seat shall be EPDM rubber and must be secured to the valve body. In sizes 20" and smaller, valves shall have bonded seats that meet test procedures outlined in ASTM D-429 Method B. Sizes 24" and larger shall be retained in the valve body by mechanical means without use of metal retainers or other devices located in the flow stream.
3. The shaft shall be Type 304 stainless steel conforming to ASTM A-276. Shaft seals shall be standard self-adjusting split V packing. Shaft seals shall be of a design allowing replacement without removing the valve shaft. Shaft seal shall be EPDM rubber.
4. Actuator components between the Input and the Stop Limiting devices shall be capable of withstanding a wrench nut input torque of 450 ft-lbs. The traveling nut must engage alignment grooves cast in both the lower portion of the actuator housing and in the cover of the actuator. Actuators that contain guide blocks for yoke nut alignment and guiding are not acceptable. All actuators shall have a built-in packing leak bypass to eliminate possible packing leakage into the actuator housing.
5. Valve operators shall be designed to hold the disc in any intermediate position between fully opened and fully closed without creeping or fluttering. Valve disc shall be lens shaped and be made from cast iron ASTM A-126 Class B in sizes 20" and smaller. Sizes 24" shall have a flow-through disc design made from ductile iron in conformance to ASTM A-536. Disc shall be furnished with Type 316 stainless steel seating edge to mate with the rubber seat in the body. Valves utilizing seat-on-disc design are not acceptable.
6. Bearings shall be sleeve type that is corrosion resistant and self-lubricating.
7. Each valve shall be bi-directionally leak tested at 150psi prior to shipment. Certified test results shall be included with each valve and be electronically submitted to SPRWS upon shipment.

3230 VALVE BOXES

Valve boxes shall be screw type Tyler Union Series 6860-HD, Star Pipe Product Series, Sima UB630-G, or approved equal, with a 5¼- inch inside diameter and be extendable from 48-inches to 102-inches. Drop lids shall be marked "WATER." Valve box parts shall be labeled and cast with raised letters identifying manufacturer, series number, part number and country where cast. Risers shall be compatible with and shall properly fit Series 6860-HD Valve Box Top Sections. Risers shall accommodate standard 5¼-inch drop lids.

Valve boxes must be installed with a valve box aligner, as shown in **Standard Plate D-2**.

3300 SERVICE AND LAWN SPRINKLER CONNECTIONS

Service and lawn sprinkler connection materials shall be suitable for use and perform properly at a minimum operating pressure of 150 psi.

3310 CURB STOP VALVES

Curb stop valves for copper service connections 2-inch and smaller shall be without drain and shall be:

- Mueller Mark II B-25154N, Minneapolis thread, or
- Ford B22, Minneapolis thread.
- AY McDonald 76104
- Legend T-5200MPNL

Curb stop valves for lawn sprinklers and air vents shall be of like materials as required for service connections, but shall have a drain (wasting valve). Curb stop valves for lawn sprinklers and air vents shall be AY McDonald 76004 or approved equal.

3320 CURB STOP BOXES

Curb stop boxes shall be A.Y. McDonald Mfg. Co. 5632a 5628a or 5631a supplied with 5627L lid or approved equal. Parts from different manufacturers may be interchanged, provided they are compatible with each other. Curb stop boxes and accessories shall be coated with an asphalt-based paint. Curb stop box must be compatible with curb stop valve.

Curb stop boxes shall telescope one foot to an extended length of 96-inches. Upper sections shall be of 1.5-inch I.D. steel pipe. Base sections and lids shall be cast of heavy, high-grade iron. Lids shall have a 2-inch brass pentagon plug, printed with the word "Water" in raised letters.

A brass Minneapolis thread centering ring from the curb stop manufacturer may be installed, if available.

In cases where the curb stop boxes are situated in asphalt or concrete paved areas, a Ford Type A, A.Y. McDonald 74M1AWO or approved equal, single lid cover or equal shall be installed a minimum of 2-inches and not more than 4- inches over the curb stop with the lid placement ¼-inch below finished grade. The pitch of the lid should match the pitch of the paved surface. Covers shall be marked "WATER" for identification purposes. Refer to **Standard Plate D-14**.

3330 COPPER MAINS AND SERVICE PIPES

Copper service tubing shall be seamless copper tubing suitable for underground water services. The tubing shall conform to the latest revision of ASTM B88, Type "K" soft.

3340 SERVICE CONNECTION SADDLES

Service Saddles shall be Mueller DR2A, A.Y. McDonald 4825A, Ford F202, JCM 402, *Smith-Blair 313*, or approved equal. Service saddle bodies shall be used for service connections on 1.5-inch and 2-inch services. Saddles shall be of ductile iron or stainless steel with synthetic rubber gaskets and with threads suitable for use with standard CC (AWWA Taper Thread) Mueller corporation valves. Saddles must have a minimum of two bands, and bands shall be bronze, stainless steel, or alloy. Nuts and bolts shall be of the same material as the bands. Smith-Blair 372 Service Saddles shall not be allowed for this application.

3350 SERVICE COUPLINGS

Couplings at the property line shall be two-part Mueller H-15425N, Mueller H-15400N, A.Y. McDonald 74753, A.Y. McDonald 74758, or equal. Soft soldered joints are not permitted. Compression couplings shall not be allowed for connections to copper pipe.

3360 CORPORATION VALVES

Corporation valves shall be Muller 300 Ball Type B-25000N, Ford Corp FB600-NL, or A.Y. McDonald Corp 74701B. Corporation valve inlets shall be threaded with standard AWWA/CC Taper. Inlet threads shall be protected in shipment by a plastic coating or other equally satisfactory means. Corporation valve outlets shall be threaded for use with flared copper tubing unless otherwise specified.

3400 FIRE HYDRANTS

Fire hydrants shall conform to the latest revision of ANSI/AWWA C502 for Dry-Barrel Fire Hydrants, except as follows:

1. Fire hydrants shall open in a clockwise direction. Acceptable hydrants are the Waterous Company WB67-250 Pacer and the Mueller Company Super Centurian 200.

All hydrants shall be provided with nozzle cap chains, the nozzle caps shall be standard nozzle caps with a 1½” (point-to-flat) pentagon nut. Nozzles shall be mechanically attached and not leaded in place. All hydrants shall have Weather Shield operating nuts.

Storz nozzle caps shall be supplied as unpainted anodized aluminum.

Fire hydrant requirements vary based on municipality; the contractor shall supply the appropriate hydrant depending on which municipality the work to be done is located in:

Municipality	Nozzle	Thread	Color
Saint Paul	(1) - 4” Storz connection (1) - 4.5” Pumper	St Paul Standard ¹	Red
Maplewood	(1) - 4” Storz connection (2) - 2.5” Discharge	National Standard	Yellow
West Saint Paul	(1) - 4.5” Pumper ²	St Paul Standard ¹	Red

	(2) - 2.5" Discharge		
Mendota Mendota Heights Lilydale Falcon Heights Lauderdale Sunfish Lake	(1) - 4" Storz connection (2) - 2.5" Discharge	St Paul Standard ¹	Red

¹: Hydrant threads shall conform to **Standard Plate D-4**

²: There are to be no Storz Connections allowed

3500 SALVAGED MATERIALS

Certain salvaged materials may be reconditioned and reused subject to approval of Engineer and SPRWS Inspector. If salvaged material is so approved, it shall be reconditioned, cleaned and recoated to the satisfaction of SPRWS Inspector. Only materials removed as part of the water main improvement project and within the improvement project boundaries will be considered for reuse.

Salvage materials shall be tested with new materials as if new.

If directed by SPRWS representative, contractor shall salvage material to remain in SPRWS possession.

3600 METRIC EQUIVALENTS

The following SI Unit sizes of pipe may be used in place of English FSS Unit sizes:

2 inch – 50 mm	16 inch – 400 mm
4 inch – 100 mm	20 inch – 500 mm
6 inch – 150 mm	24 inch – 600 mm
8 inch – 200 mm	30 inch – 750 mm
12 inch – 300 mm	36 inch – 900 mm

3700 CATHODIC PROTECTION SYSTEM

Cathodic protection materials shall be new and shall remain in original sealed packaging until installation.

3710 GALVANIC MAGNESIUM ANODE

Anodes shall be cast or extruded on a full length galvanized-steel core, shall conform to ASTM B843, and shall be composed of the following:

- Manganese 0.50-1.3%

- Silicon 0.05 max
- Iron 0.03% max
- Nickel: 0.001 % max
- Copper 0.02% max
- Aluminum 0.01% max
- Others each 0.05% max
- Magnesium remainder

Anodes shall be prepackaged in a water permeable cloth ~~or paper bag~~ containing a low resistivity backfill material, consisting of 75% hydrated Gypsum, 20% bentonite and 5% sodium sulfate. A minimum of 20 feet of unspliced No. 10 AWG copper wire with ~~THWN~~ THHN insulation shall be attached to the anode. Anode lead wires shall be black in color.

Standard anode of 32-lb bare weight (70-lb packaged weight) shall be used unless otherwise specified by SPRWS inspector.

3720 TEST STATIONS

Test Station Wiring

Wires utilized for test stations shall be solid single conductor copper wire type THHN insulation, No. 10 AWG. Pipe lead wires shall be white in color and reference electrode lead wires shall be red in color.

Test Station Panel Boards

Test station terminal boards shall be made of polycarbonate material and integral to the test station cover and not loose. Five double-nutted plated brass studs shall be installed on the panel boards, as shown in **Standard Plate D-15**. Tinned copper ring terminals shall be soldered to the ends of wires terminated in the test station. All panel boards shall accommodate a shunt.

Test Station Shunts

Shunts for all sacrificial anode test stations shall be 0.01 ohm, 6 ampere capacity, manganin wire type, unless otherwise specified.

Test Station Box

The box for test stations shall be an H20 rated flush mount style utility box, Bingham & Taylor or approved equal. The box covers for insulating test stations shall be cast iron with "CP TEST" in raised lettering.

Test Station Reference Electrode

The reference electrode shall be composed of Copper-Copper Sulfate and shall have an AWG No. 10 lead wire.

Borin Stealth 2 model SR-007-CUY or approved equal reference electrode shall be used.

3730 JOINT BONDING

Wires for joint bonds shall be single conductor copper wire Type HMW/PE insulation No. 8 AWG.

3740 ISOLATION JOINTS

Isolation joints shall be installed where new cathodically protected pipe meets existing iron pipe. Such joints shall consist of 3 feet of matched size C-900 PVC pipe. Connections to iron pipe shall be made consistent with these standards. A test station shall be installed at each isolation joint.

3750 INSULATING FLANGE

Insulating flange gaskets shall be G-10 glass epoxy. Sleeves shall be full length and of a material indicated by the manufacturer as suitable for domestic water. Flange bolts, nuts and washers shall be stainless steel. Contractor shall provide two sets of 1/8 inch G-10 glass epoxy washers. Insulating sleeves shall be spiral wound Mylar, 1/32 inch thick.

Underground dielectric insulating flanges shall be covered with Trenton Primer and #1 Wax Tape or approved equal. Overwrap shall be plasticized PVC tape with natural and synthetic rubber adhesive.

3760 EXOTHERMIC WELDS

Cable connections for anodes and test stations to pipe and fittings shall be made with exothermic weld kits specifically designed by the manufacturer for welding the type of materials. Connections to ductile iron and cast iron pipe or fittings shall use the weld metal and mold for exothermic connections to cast iron pipe. The mold and weld metal shall be supplied by the same manufacturer. Weld metal shall be type XF manufactured by Thermoweld or approved equal. All welds shall be made with copper wire sleeves.

All exposed wires and welds shall be protected with an adhesive rubber Thermite Weld Cap, or approved equal.

3770 BITUMASTIC COATING

Bitumastic Coating shall be TE Mastic, as manufactured by Tapecoat Company, Bitumastic 50, or approved equal. Holidays in the protective coating shall be repaired in the field as directed.

- END OF DIVISION 3000 -

DIVISION 4000: INSTALLATION OF PIPE AND APPURTENANCES

4100 GENERAL INFORMATION

The latest revision of ANSI/AWWA C600 shall apply.

No valve, hydrant or other control on either the existing or new water system shall be operated for any purpose by Contractor. Valves shall only be operated by or under the direction of SPRWS Inspector. No section of water main will be placed in permanent service by SPRWS until that section of main and appurtenances has been inspected, tested and disinfected to the approval of SPRWS Inspector.

Contractor shall coordinate with SPRWS inspector in the event that inspector is not able to be on site for any portion of the water main installation. The inspector will determine any acceptable alternative methods to their visual inspection in these scenarios. Pipe may not be concealed until properly inspected and approved. If the contractor does not comply and the inspector is unable to view the installation, they may ask the contractor to dig up the portion of water main that was not properly inspected.

4110 PRECONSTRUCTION REQUIREMENTS

Experience and Qualifications

The Contractor shall have a minimum of four years of experience in water main construction and at least eight miles of pipe installed. The work experience must have been performed under the company name. The Contractor shall provide qualifications to the Engineer upon request.

All persons installing water main shall hold a valid pipelayers certification. Acceptable certifications include the MUCA pipelayers certification, the local laborers union pipelaying courses or approved equal.

Preconstruction Meeting

A preconstruction meeting attended by Contractor, Engineer and SPRWS Inspector is required prior to start of construction. If water facilities are proposed for installation in or across a state or county highway, the state or county highway maintenance Engineer shall be invited to the meeting. Representatives of utility companies having facilities within the project area shall also be invited to the meeting.

At the preconstruction meeting, SPRWS will provide Contractor with a list of existing gate boxes and stop boxes in the construction area.

Existing Facilities

Contractor is responsible for the condition of existing water facilities in the construction area. Throughout construction, Contractor shall maintain access to all facilities and shall maintain all facilities in a condition no less than was found prior to construction.

The SPRWS will provide the Contractor with measurements or drawings indicating the location of gate valves, air vents, and other water system items. It is the Contractor's responsibility to take ties or make markings so that these items can be located during all phases of construction, including grading and placement of non-wear and wear courses. The Contractor will make specified gate valves, air vents, and other water system items accessible to SPRWS personnel for operation or testing. Gate valves, air vents, and other water systems items that are found inaccessible shall be raised and made accessible by the Contractor at SPRWS staff request in a timely manner. If facilities cannot be raised contractor, SPRWS will raise inaccessible items at a Time and Materials cost to the contractor.

Prior to construction, SPRWS will attempt to locate and repair existing valve boxes and stop boxes in the construction area. Contractor may inspect these facilities with its own forces and notify SPRWS Inspector of deficiencies.

Initial Inspection

Contractor, along with SPRWS Inspector, shall inspect all valve and stop boxes in the construction area, and any that are found to be damaged, incomplete or buried shall be noted. If Contractor fails to schedule an inspection prior to construction, any facilities found to be damaged or broken within the construction area shall be assumed to have been damaged by Contractor and Contractor shall be responsible for repairs to such facilities.

Contractor shall replace, at the identified bid cost, all valve-housing top sections found to be broken during the initial inspection.

4120 NOTIFICATION

Contractor shall notify SPRWS at least 48 hours in advance of construction so that staff can be assigned to the project. Once the project begins, notification is required 24 hours before each new activity.

4130 MATERIALS

Contractor shall furnish and install only the specified materials approved by SPRWS. SPRWS will be responsible for furnishing any material required for work to be performed by SPRWS.

Materials furnished by Contractor must be inspected by SPRWS Inspector before installation. Any materials installed without prior inspection may be ordered removed for inspection and approval.

4140 INTERRUPTION OF WATER SERVICE

SPRWS Inspector or SPRWS Foreman shall notify the Engineering office of any host community in which a water main shutdown becomes necessary. Consumers affected by such operation shall be notified by SPRWS personnel a minimum of 24 hours before the operation and advised of the probable time when the service will be restored. Where larger services or commercial properties are affected by the shutoffs, a minimum of 3 days' notice shall be given. After-hours work may be required if certain properties cannot be out of service during normal

work hours. In the event a main must be placed out of service for more than a single 8 hour period, temporary service must be installed by SPRWS to all affected consumers at the expense of the project. For extended main shutdowns, contractor must provide SPRWS 2 weeks' prior notice for residential shutdowns, and 3 weeks' prior notice for commercial shutdowns.

4150 CORROSION CONTROL

All pipe and appurtenances shall be protected by the use of enhanced V- Bio polyethylene encasement in accordance with the latest revision of ANSI /AWWA C105/A21.05. If coating or corrosion control is determined necessary by SPRWS, they shall conform to recognized industry standards and codes including AWWA, National Association of Corrosion Engineers (NACE), SSPC (Society of Protective Coatings), and NSF as applicable.

4200 HANDLING PIPE AND ACCESSORIES

4210 CARE IN HANDLING

Pipe, fittings, valves, hydrants, appurtenances and accessories shall be unloaded at the point of delivery, hauled to and distributed at the site of the project by Contractor, unless otherwise directed by SPRWS Inspector, and they shall at all times be handled with care to avoid damage. In loading and unloading they shall be lifted by hoist, slid, or rolled on skidways in such a manner as to avoid shock. Under no circumstances shall they be dropped. Pipe handled on skidways must not be skidded or rolled against pipe already on the ground. Additionally, plastic pipe shall be handled according to AWWA M55: PE Pipe – Design and Installation. Metal chokers shall not be allowed when lifting PVC pipe as it can gouge the pipe and create weak points.

4220 PLACEMENT OF PIPE

In distributing the material at the site of the work, each piece shall be unloaded opposite or near the place where it is to be laid in the trench.

4230 CARE OF PIPE COATING

Pipe shall be handled in such manner that a minimum amount of damage to the coating will result. Damaged coating shall be repaired in a manner satisfactory to SPRWS Inspector.

4240 PIPE STAGING

Pipe shall be placed on the site of the work parallel with the trench alignment and with bell ends facing the direction in which the work will proceed, unless otherwise directed by SPRWS Inspector. All pipe shall be blocked and stored off the ground away from the flow path of rainwater runoff until the time of installation. All pipe ends shall be fitted with a plastic cap or plug immediately upon washing according to the provisions below. Stored pipe shall be inspected daily to ensure caps remain in place until they are installed.

4250 PIPE AND APPURTENANCE CLEANLINESS

All pipes shall be washed within the entire barrel using a solution of water and detergent prior to being installed. Pressure washing of pipe shall be performed with caution to ensure no damage is done to the cement mortar lining. Fittings and valves shall be cleaned on-site in a similar manner and sprayed with chlorine solution prior to installation. Contractor shall prevent materials from contaminating or potentially contaminating the interior of all pipes, fittings and other accessories during storage, construction, or repair, while materials are located at the construction site.

4260 PIPE LINING

Pipe with damaged lining will be rejected. No repair will be acceptable.

4300 ALIGNMENT AND GRADE

4310 GENERAL

Water mains and appurtenances shall be installed only in the location and to the grade shown on construction plans approved by SPRWS. Valves, fittings and hydrants shall be installed at approved locations. Any deviation from the approved plans must be submitted to SPRWS for review and approval prior to construction.

If a water main is installed within an easement, alignment hubs must be set by a surveyor to identify the easement limits and the water main alignment. Grade stakes are required in intervals of 25 feet, or as requested by SPRWS Inspector. Alignment hubs and grade stakes shall be maintained until the installation is complete.

4320 PROTECTING UNDERGROUND AND SURFACE STRUCTURES

Temporary supports, adequate protection and maintenance of underground and surface utility structures, drains, sewers, house and service connections for both sewer and water, and other obstructions encountered in the progress of the work shall be furnished by Contractor at its expense under the direction of Engineer, unless otherwise provided for. Adjustment of in-place, underground water facilities shall be accomplished by SPRWS unless contractual arrangements are made. Scheduling of SPRWS adjustments must be coordinated through SPRWS Inspector. Refer to **Section 2530** for undermining requirements and Section 4570 for offset requirements.

4330 OBSTRUCTIONS CAUSED BY OTHER UTILITIES

Wherever existing utility structures, branch connections leading to main sewers or to main drains, or other conduits, ducts, pipes, or structures form obstructions to the grade and alignment of the water main to be laid, they shall be permanently supported, removed, relocated or reconstructed by Contractor through cooperation with the owner of the utility, structure or obstruction involved. In those instances where relocation or reconstruction is impractical, a deviation from the line and grade may be ordered by Engineer, if approved by SPRWS Inspector.

Wherever possible, existing utility structures and appurtenances will be located in advance of trench excavation and must be properly marked. Contractor shall not alter any existing utility lines unless it is determined by Engineer that it will be necessary in order to install the new water main. Utility lines that are damaged by Contractor shall be repaired or replaced by said utility at Contractor's expense, unless the Utility states otherwise.

Crossings of utilities or structures not shown on the construction plans shall be reviewed with Engineer and SPRWS Inspector prior to construction.

4340 DEVIATION WITH ENGINEER'S CONSENT

Construction shall not deviate from plans and specifications approved by SPRWS, except with the approval of SPRWS Inspector and the consent of Engineer. Any changes requiring revision to the plans originally approved by SPRWS must be resubmitted for approval prior to construction.

Failure to comply with this requirement shall be cause to deny acceptance of the installation until such time as remedial action is completed by Contractor and approved by SPRWS Inspector.

4350 PIPE COVER

Water mains shall be laid to the depth shown on the drawings or at such other depth as established by Engineer or SPRWS Inspector, in order to connect the new pipe to existing water mains. Refer to **Section 2240**.

4400 EXCAVATION AND PREPARATION OF TRENCH

The trench shall be dug to the alignment and depth required and only so far in advance of pipe laying as Engineer or SPRWS Inspector shall permit. The trench shall be so braced and drained that workers may work therein safely and efficiently. It is essential that the discharge from pumps be lead to natural drainage channels, drains, or to sewers.

4410 EXCAVATION SAFETY

Contractor shall follow OSHA Standards for excavations, trenching and shoring (Federal Register Part 1926, Subpart P). Contractor shall protect workers against cave-ins in excavations by adequate protective systems, such as trench boxes, shoring, allowable sloping or other. Contractor shall be responsible for the excavation throughout the life of the trench. Contractor shall have a duly authorized Competent Person on site. The Competent Person shall be capable of identifying hazards and taking prompt corrective measure to eliminate them. Inspections shall be in accordance with OSHA Standard Section 1926.651 (K) (1). All soils shall be classified as Type C unless otherwise determined by acceptable documented visual and manual tests. SPRWS Inspector, Engineer or SPRWS Foreman shall have the authority to require the use of a trench box or other protective systems.

1. Excavation requirements

Water Service Trench

Trench box with 4 shored sides, with an approximate width of 3 feet and a length of 5 feet to minimize removals. Trench box is required at the water main and at property line or boulevard stop box.

Water Utility Hole

Trench box with 4 shored sides, adjustable to an approximate width of 5 feet and a length of 7 feet. This is also required on miscellaneous holes such as valve or stop box work.

Hydrant Excavation

Trench box with 3 shored sides, adjustable to an approximate width of 6 feet and a length of 8 feet. Hydrant trench boxes will be used in conjunction with water main trench boxes when installing hydrants from a new main.

Water Main Trench

Trench box with 2 shored sides, minimum length of 24 feet. The inside width of the trench box shall not exceed 6 feet when installing water mains 12-inch and smaller, or 8 feet inside width when installing water mains larger than 12-inch.

2. Trench box requirements

Trench boxes shall meet OSHA requirements and manufacturer's tabulated data requirements, as referenced on the box. A four-sided trench box is required on all excavations deeper than five (5) feet, where underground work or inspection is to be performed by SPRWS. Ladders are required and must extend three feet above the surface of the trench. Sidewalks, pavement, ducts and appurtenant structures shall not be undermined, unless a support system or another method of protection is provided. Trenches in excess of 20 feet in depth must be signed off by a registered professional engineer. Excavated material must be kept a minimum of two (2) feet from the edge of the trench. Trench boxes shall be sized to minimize removals. Contractor shall provide for protected trench ingress and egress by means of a ladder or properly sloped trench walls.

Where field conditions prohibit the use of a trench box, Contractor shall be responsible to install an excavation protection system meeting OSHA regulations.

4420 WIDTH

The trench shall be ample in width to permit the water main to be laid and jointed properly and the backfill to be placed and compacted properly. The trench shall be constructed in compliance with **Section 4410** and the maximum clear width of the trench at the bottom shall be not more than 2 feet greater than the pipe diameter.

4430 PIPE FOUNDATION

The trench, unless otherwise specified, shall have a flat bottom conforming to the grade to which the pipe is to be laid, with bearing for the full length of the pipe. Bells shall be hand dug to allow bearing along the length of the pipe.

4440 PIPE FOUNDATION AND BACKFILL IN POOR SOIL

When the trench bottom uncovered at subgrade is found to be unstable or to include ashes, cinders, refuse, vegetable or other organic material, or large pieces or fragments of inorganic material, a further depth and/or width shall be excavated, or other approved means shall be adopted to assure a firm foundation for the pipe, as ordered by Engineer. The depth of excavation and backfill material used for replacement shall be as ordered by Engineer and approved by SPRWS Inspector. Protective measures required for pipe installation in corrosive soils are found in **Section 4150**.

4450 PIPE FOUNDATION IN WET SOIL

Where either SPRWS Inspector or Engineer determines that the amount of moisture in the pipe foundation soil is sufficient to require stabilization, Contractor shall stabilize the pipe foundation with 1½-inch clear river rock installed to a depth determined by the requiring entity.

4460 PIPE FOUNDATION AND BACKFILL IN ROCK

Ledge rocks, boulders and large stones shall be removed to provide at least 6-inches clearance from all parts of the pipe, and appurtenances. Adequate clearance for properly jointing the pipe shall be provided at bell holes. The pipe shall be laid on a 6-inch bed of granular material to assure the barrel of the pipe will have a uniform bearing for its full length. The trench shall be backfilled with granular material to a depth of 1 foot above the top of the pipe. Excavated rock shall be removed from the job site. Backfill material shall be compacted with hand operated equipment up to 1 foot above the pipe. Remainder of backfilling shall be performed in accordance with **Sections 4920** and **4930**.

4500 INSTALLATION OF PIPE

4510 MANNER OF HANDLING PIPE AND ACCESSORIES

Proper implements, tools and facilities satisfactory to SPRWS Inspector or Engineer shall be provided and used by Contractor for the completion of the work without interruption to existing service by Contractor. Pipe and fittings shall be carefully lowered into the trench piece by piece, in such manner as to prevent damage to pipe lining or pipe coating. Under no circumstances shall pipe or accessories be dropped or dumped into the trench. Any defective, damaged or unsound pipe shall be rejected. Valves should be wrapped in a protective material until installed to prevent foreign materials from damaging the valve disc or seat. Valves should be opened, operated and inspected for damage or imperfection prior to installation and any not serviceable, in the opinion of SPRWS Inspector or Engineer, shall be rejected.

4520 PIPE INSTALLATION CLEANLINESS

Foreign matter or dirt shall be removed from the inside of the pipe, valves and hydrants before lowered into position in the trench, and it shall be kept clean by approved means during and after installation.

Precautions shall be taken to protect the interiors of pipes, fittings and valves against contamination. Openings in the pipeline shall be closed with watertight plugs when pipe installation is interrupted or stopped. If water accumulates in the trench, the plugs shall remain in place until the trench is dry.

Jointing of pipe in the trench shall be completed before work is stopped.

4530 CUTTING PIPE

When it is necessary to cut pipe, the end shall be cut as nearly square as possible (no diagonal cuts) and dressed with a file or grinder. Slip joint pipe ends shall be beveled. Before assembling, a depth mark must be placed on field cut pipe to assure proper homing of the joint. When a nipple is used in conjunction with a fitting, the minimum length shall be 2 feet. When a nipple is used in conjunction with straight pipe, the minimum length shall be determined by SPRWS Inspector, but in no case shall the length be less than 2 feet.

4540 PIPE INSTALLATION

Unless otherwise directed, pipe shall be laid with bell ends facing the direction in which the work will proceed, and for lines on an appreciable slope, bells shall, at the discretion of Engineer, face upgrade.

4550 PERMISSIBLE DEFLECTIONS AT JOINTS

Wherever necessary to deflect pipe from a straight line, either in the vertical or horizontal plane to avoid obstructions or for other reasons, the degree of deflection shall be as directed by Engineer and approved by SPRWS Inspector. However, in no case shall the deflection be greater than allowed in the latest revision of AWWA C600. Deflection of mechanical joint pipe shall be made after joint assembly but before bolts are tightened. Pipe deflection around curved streets shall be in accordance with **Section 2245**.

4560 UNSUITABLE CONDITIONS FOR LAYING PIPE

No pipe shall be laid in water, or when the trench or weather conditions are unsuitable for such work, except with the permission of Engineer or SPRWS Inspector.

4570 UTILITY OFFSETS

Unless alternative arrangements are approved by the SPRWS representative, water main shall be offset under the following conditions:

1. Water mains 12 inches and smaller where there is 8 inches or less of clearance between the top of the water main and the bottom of the utility.
2. Water mains 16 inches and larger where there is 4 inches or less of clearance.
3. Any water main that has less than 16 inches of clearance between a utility that is subject to cold, such as a storm sewer. Refer to Section 2520 for insulation requirements.

When there is an anticipated water main offset, it is the Contractor's responsibility to expose the top of the water main and to supply the SPRWS representative the following information at no additional cost:

- Sewer Invert Elevation
- Size and Type of Sewer
- Elevation of top of the Water Main
- Finished Ground Elevation

Water main offsets shall be installed in accordance with **Standard Plate D-10**.

If the section AB is longer than a standard length of pipe, no slip joint will be allowed. *In addition, anodes shall be installed for offsets of existing watermain. Refer to Section 3710 for magnesium anode requirements.*

Elevation of in-place water pipes as shown on plans will **not** be accepted as a means to determine the need for an offset as they do not typically reflect actual depth.

When an offset of in-place water pipe is performed by SPRWS, including compacting suitable material under and around the offset excavation, the contractor shall be responsible for traffic control, excavation, pipe handling, backfilling, restoration and removal of old pipe and fittings. Contractor shall provide additional workers to direct Contractor's equipment operator(s) during excavation, pipe handling and backfilling operations. Contractor shall allow SPRWS sufficient time to complete its work.

Contractor shall locate all underground utilities and shall be responsible for damage to underground utilities caused by or arising from its excavation.

4600 JOINTING PIPE

The number of joints in any section of pipe shall be kept to a minimum.

4610 PREPARATION OF PIPE

Before laying pipe, all lumps, blisters and excess asphaltic coating shall be removed from the bell and spigot ends of each pipe. The pipe shall then be wire brushed and wiped clean dry. Pipe ends shall be kept clean until joints are made.

Polyethylene encasement shall be used with all ductile iron pipe installments; as well as with all ductile iron fittings and valves used in plastic pipe installations. The encasement shall be installed such that all metallic surfaces and appurtenances of the pipe are covered with the encasement and secured using polyethylene compatible adhesive tape. All rips, tears, and other damage shall be repaired with compatible adhesive tape.

4620 ASSEMBLY OF MECHANICAL JOINT PIPE

The inside of the socket and the outside of the spigot end shall be wiped clean and a thin film of gasket lubricant shall be applied to the inside gasket surface and spigot end of the pipe to improve gasket seating. Place the gland on the spigot end of the pipe with the lip extension toward the spigot end, followed by the gasket with the narrow end of the gasket toward the spigot end of the pipe. The spigot end of the pipe shall be entered into the socket with care to keep the joint clean and free of trench material. Press the gasket firmly and evenly into the gasket recess, keeping the joint straight during assembly. Push the gland toward the bell and center it around the pipe with the gland lip against the gasket. Align bolt holes and insert bolts with bolt heads behind the bell flange, and tighten opposite nuts to keep the gland square with the socket. Tighten nuts according to the following table:

Bolt Diameter	Torque, foot pounds
5/8"	45 - 60
3/4"	75 - 90
1"	85 - 90
1 1/4"	105 - 120

4630 ASSEMBLY OF PUSH-ON JOINT PIPE

The inside of the socket and the outside of the spigot end shall be thoroughly cleaned to remove oil, grit, excess coating and other foreign matter. The circular rubber gasket shall be flexed inward and inserted in the gasket recess of the bell socket. A thin film of gasket lubricant shall be applied to the inside gasket surface and spigot end of the pipe. Gasket lubricant shall be as supplied by the pipe manufacturer and approved by Engineer or SPRWS Inspector. The spigot end of the pipe shall be entered into the socket with care used to keep the joint from contacting the ground. The joint shall then be completed by forcing the plain end to the bottom of the socket with a forked tool or jack-type tool or other device approved by Engineer. Pipe that is not furnished with a depth mark shall be marked before assembly to assure that the spigot end is inserted to the full depth of the joint. Fieldcut pipe lengths shall be filed or ground to resemble the spigot end of such pipe as manufactured. Complete assembly instructions are available from the pipe manufacturer.

4640 CONDUCTANCE OF PLASTIC PIPE

Molecularly Oriented Polyvinyl Chloride (PVCO)

PVCO pipe shall be installed in accordance with the latest revision of ANSI/AWWA C909.

Main Tracer Wire

All pipe shall be installed with one tracer wire. Tracer wire shall be continuous, not spliced, and shall be placed and stay true on the crown of the pipe and attached to the pipe every ten feet.

Outlet Tracer Wire

Tracer wire for service connections, hydrant branches, tees and other outlets shall be connected to the main tracer wire with a direct burial, split-bolt connector Brundy type KS15 or approved equal. All connections shall be coated with a urethane coating CRC Seal Coat No. 18410 or approved equal.

Connection to copper service pipe shall be accomplished by stripping the wire's plastic sheath and connecting it to a grounding clamp. Grounding clamp shall be direct burial (e.g. Brundy type C-11D or C-22D) or approved equal.

High Density Polyethylene (HDPE)

HDPE pipe shall be joined only by thermal butt fusion. HDPE pipe and transition sections shall be installed in accordance with the latest revision of ANSI/AWWA C906.

Main Tracer Wire

All pipe shall be installed with 2 tracer wires of material as specified in **Section 3160**. Tracer wires shall be continuous and not spliced.

All tracer wire shall be traceable at a frequency of 512 to 577 Hz transmitter. Tracer wire shall be continuous for the length of the pipe run and shall **not** be bonded to iron fittings.

Hydrant Tracer Wire

Tracer wire shall daylight at each hydrant location and shall be concealed with a hydrant tracer wire test box. The tracer wire test box shall be secured to the hydrant flange using a bracket, as specified in **Section 3160**.

4650 JOINT RESTRAINT

Tees, crosses, plugs, caps, valves, hydrants and all bends shall be securely anchored as specified in **Section 2250**.

4660 CONCRETE MAIN

When connecting to concrete main, refer to the Thompson Pipe Group Concrete Pressure Pipe Engineering Manual, 11th edition, section 3.02 INSTALLING PRESTRESSED CONCRETE CYLINDER PIPES AND FITTINGS.

Refer to section 10, Adapters, for information regarding adapters needed to fit various types of joints.

4700 SETTING VALVES, VALVE BOXES, SERVICE STOPS, HYDRANTS AND FITTINGS

4710 JOINTING

Valves and pipe fittings shall be set and jointed to new pipe in the manner previously specified for cleaning, laying and jointing pipe. Main line valves shall be installed in the closed position, and hydrant valves installed in the open position unless instructed otherwise by SPRWS Inspector. Valves at the end of a line shall be restrained in accordance with **Standard Plate D-11**.

4720 VALVE BOXES

Cast iron valve boxes shall be firmly supported and maintained centered and plumb over the wrench nut of the valve with the use of a valve box aligner, and valve box covers between ½-inch below flush to flush with the surface of the finished pavement. Refer to **Standard Plate D-2**. If a project will extend over more than one construction season, valve boxes on water mains already in service shall be made accessible during the winter season.

4730 SERVICE CONNECTION BOXES

Service connection stop boxes shall be firmly supported and installed plumb, with the cover flush with the boulevard surfacing.

For services 2-inch and smaller, stop boxes shall be marked with a 4-foot long, 2x2 wood timber. The timber shall extend 2 feet above grade after backfilling and shall have the service address number written on the timber. For services larger than 2-inch, an 8-foot long 4x4 wood timber shall be placed at the end of the service pipe. The timber shall extend 4 feet above grade after backfilling and shall have the service address number written on it. Metal markers are **not** permitted.

4740 HYDRANT LOCATIONS

Hydrants shall be installed at the locations shown on the approved plans and as staked in the field by Engineer. Any variance from the locations shown on the plans must be approved by Engineer and SPRWS Inspector. Refer to **Section 2410** for acceptable hydrant locations.

4750 HYDRANT POSITION AND ELEVATION

Hydrants shall stand plumb. Three-nozzle hydrants shall be installed with small nozzles parallel with the curb and the pumper nozzle pointing perpendicular to the curb. Two-nozzle hydrants shall face at a 45 degree angle to the curb. Hydrants shall conform to the established grade, with nozzles at least 16-inches above the finished grade. The hydrant traffic flange shall be not less than 2-inches nor more than 4-inches above the established grade. Dishing out

around hydrants is **not** allowed. Refer to **Standard Plate D-3**. Offset of hydrant lead may be necessary to have hydrant at correct grade. “Cutting down” of hydrant barrel to grade is not approved.

4760 HYDRANT CONNECTION TO MAIN

Hydrants shall be connected to the main with a 6-inch ductile iron branch controlled by an independent 6-inch gate valve, except as otherwise directed or shown on the plans. Refer to **Standard Plate D-3**. The preferred location of the hydrant control valve is 2 feet in front of the hydrant. If hydrants are connected to 16-inch and larger water mains, the hydrant branch shall be offset down, if necessary, to produce 8 feet of cover. All hydrants constructed off of new water main shall have a bury depth of 8’9 feet. When working in project areas with watermain shallower than the standard depth, hydrants with shorter bury depth may be approved by SPRWS inspector or engineer.

4770 HYDRANT SETTING

Hydrants shall be set as shown on **Standard Plate D-3**.

A minimum ½ cubic yard of coarse filtered aggregate shall be placed around the base of the hydrant to at least 6-inches above the hydrant weep holes. The aggregate shall be completely covered with 8 mil plastic. Drip boxes constructed of 2”x12” treated wood may be used in lieu of aggregate as approved by SPRWS.

Joint restraint shall be provided as necessary for thrust resistance at hydrants and hydrant valves. Blocking the hydrant is **not** permitted. Hydrant weep holes shall be plugged in areas where ground water is encountered, as directed by SPRWS Inspector. A red “Pump After Use” ring stating that the hydrant shall be pumped out after use shall be placed on hydrants with plugged weep holes. Rings can be obtained from SPRWS.

4780 PLUGGING DEAD ENDS

Restrained mechanical joint plugs or caps shall be installed on dead end pipes, dead-end tees and dead-end crosses. Where flushing the pipe cannot be accomplished by other means, a corporation valve shall be installed on the plug or cap. (See 5210.)

4800 CATHODIC PROTECTION INSTALLATION

Contractor shall prevent electrical contact between the metallic pipe and/or fittings cathodically protected and other existing buried metal structures at time of installation of cathodic protection system.

4810 GALVANIC MAGNESIUM ANODES

Excavate a hole to a minimum of 3 inches larger than the anode diameter, and to a depth of one foot below the pipe or fittings to be protected, as shown in **Standard Plate D-15**. Excavate the lead wire trench to the depth indicated on the details shown on the plans. Do not lift or support anode by the lead wire. Anodes shall be activated by applying a minimum of 2 gallons

of water over the backfill material upon installation and prior to backfilling. Plastic packaging shall be removed from the anode prior to installation.

4820 WIRES

Wires buried in the ground shall be laid straight, without kinks, and provide a minimum cover of 24 inches. Fill material around the wires shall be free from stones, roots, or other material that might damage the insulation of the conductors. Each cable run shall be continuous in length and free of joints or splices, unless otherwise specified by SPRWS Inspector. Care shall be used during installation to avoid punctures, cuts and similar damage to the insulation. Any damage to insulation will require replacement of the entire cable length by contractor. Copper ring terminals shall be crimped and soldered to the ends of the test leads, drain wires and anode leads terminated in the test station. All wire test leads and anode leads shall extend a minimum of 18 inches above grade after connection to the test station panel board. No wire bend shall have a radius less than eight (8) times the diameter of that wire. Copper terminal rings sized for wire and stud shall be used to make all wire connections to terminal studs.

4830 JOINT BONDING

For metallic pipe, joint bond all non-welded rubber gasket joints, mechanical joints, and fusion-bonded epoxy flanged fittings to provide electrical continuity between all metallic sections of the water main to be cathodically protected.

Joint bonds shall be installed with a wire loop extended above the bonded joint. The overall length of the conductor shall permit sufficient flexibility of each fitting across the joint without transferring any tensile strength to the bond cable. Cable to fitting connections shall be in conformance with these specifications. Coat all exposed surfaces of each fitting with liquid epoxy patch kit and cover all welded connections with a bitumastic material and polyethylene weld cap.

4840 TEST STATION

Two test leads shall be connected at the nearest pipe to the test station. All connections of test lead wires to metal surfaces at the point of connection shall be cleaned by grinding or filing prior to welding the conductor. Test stations shall be installed flush with the ground or pavement.

4850 INSULATED FLANGED JOINTS

Insulating components of each insulation flange kit shall be cleaned of all dirt, grease, oil, and other foreign materials, immediately prior to assembly.

4860 EXOTHERMIC WELDS

Coating materials shall be removed from the surface over an area just sufficient to make the connection. The steel surface shall be cleaned to white metal by grinding or filing prior to welding the connector. Resin impregnated grinding will **not** be allowed. No connections to the structures or piping shall be buried until the SPRWS inspector has inspected the connections

and given permission to backfill. Connections made in violation to this provision will be rejected. Cover all welded connections with a bitumastic material and polyethylene weld cap.

4870 PETROLATUM WAX TAPE

Wire brush dirt and loose rust from substrate; apply primer by brush and work in to obtain a full film cover on substrate. Install mastic to contour all sharp edges and irregular profiles. Spirally apply tape with minimum 55% overlay smooth tape to exclude voids and seal overlaps.

4900 BACKFILLING AND CLEAN UP

4910 BACKFILL PROCEDURE AT PIPE ZONE

Pipe encasement material shall be entirely free of rocks, lumps or frozen material in accordance with MnDOT 3149.2.B.1. Encasement shall be a two-stage procedure.

Stage One

Pipe encasement material shall be carefully deposited simultaneously on both sides of the pipe for the full width of the trench to the top of the pipe. The backfill material shall then be thoroughly compacted with hand-operated mechanical equipment before proceeding to stage two.

Stage Two

Pipe encasement material shall be carefully deposited directly over the pipe to a depth of 12-inches above the top of the pipe as a protective barrier prior to backfilling above the pipe zone.

Contractor may at its option, or as required by SPRWS Inspector, leave the joints exposed for examination during the specified pressure test.

No organic material, clay or other cohesive material that is known to be corrosive, which may be excessively expansive, or which is suspected of being such material in the opinion of Engineer or SPRWS Inspector, shall be permitted at the pipe zone. Refer to **Section 4150**.

When native base materials contain rocks, soils are wet or unstable, or flexible pipe is being installed, 6" of material in accordance with MnDOT 3149.2.B.1 shall be placed under the pipe as bedding. Refer to **Standard Plate D-5**.

4920 BACKFILL MATERIAL EXCLUSION ABOVE THE PIPE ZONE

No rocks, concrete or pieces of blacktop greater than 6-inches in dimension shall be permitted within the backfilling above the pipe zone. Rocks, concrete or pieces of blacktop smaller than 6-inches may be included in backfill if amounting to less than 10 percent by volume of the material used. Corrosive soil, organic material and trash are **not** permitted in the backfill material.

4930 BACKFILL PROCEDURE ABOVE THE PIPE ZONE

Backfill shall be thoroughly compacted to the satisfaction of Municipal or Project Inspector or Engineer. For each 12” lift during the backfill process, a 3-foot radius around each valve box, hydrant and stop box shall be thoroughly compacted ~~to 95% compaction~~ conforming to MnDOT standards with hand operated mechanical equipment. Puddling with water will not be permitted. In a city street, compaction shall conform to the local city standards and shall be subject to approval by said local authority.

4940 CLEAN UP

Pipeline material left on the ground, tools, temporary structures, all dirt, rubbish and excess earth and rock from excavation shall be removed from the area by Contractor. The construction site shall be left clean to the satisfaction of SPRWS Inspector and Engineer.

- END OF DIVISION 4000 -

DIVISION 5000: TESTING OF PIPE, SERVICE CONNECTIONS, AND APPURTENANCES

Water main, service connection, and appurtenance testing shall be conducted in the following order:

1. Filling the main
2. 24 hr disinfection contact time
3. Flushing the main
4. Hydrostatic test
5. 16 hr minimum wait time
6. Bacteriological test
7. Conductivity test

5100 FILLING AND CHLORINATION OF COMPLETED MAINS

After the main has been installed and backfilled; it shall then be filled and disinfected slowly with water from an uncontaminated source. The velocity of the water must not exceed 1-foot per second. Air vents or hydrants at high points of each valved section shall be opened while filling. All valves isolating the newly installed main from the existing system shall be locked out and tagged out to prevent unintentional release of elevated chlorine residual water used for disinfection.

5110 PROCEDURE

Only the chlorination methods specifically listed within this Section are approved for use. Chlorination is required for new water mains before they are placed in service. Procedure for disinfection shall be governed by the latest revision of ANSI/AWWA C651. A 1-inch or

smaller tap shall be used by Contractor for testing or chlorination. When work is complete, the corporation shall be replaced with a suitable brass plug.

5120 CHLORINATION TO BE PERFORMED BY CONTRACTOR

Labor, equipment, and tools necessary to make the required chlorination applications shall be furnished by the Contractor. Chlorination work shall be performed under the direction of SPRWS Inspector.

If the main is not placed in service within 15 days of initial chlorination, samples shall be taken to determine if re-chlorination is necessary before placing main in service.

5130 CONTINUOUS FEED (LIQUID) METHOD

A solution of water containing at least 100 parts per million of chlorine shall be fed into the line to be treated until the line is completely filled. This solution shall be retained in the line a minimum of 24 hours at which time the residual chlorine content in the line must not be less than 10 parts per million on any part of the line. This method is recommended for installations regardless of size of pipe or length of line.

5140 TABLET (GRANULAR) METHOD

During installation, sufficient tablets shall be cemented to the top of each pipe using only a SPRWS approved NSF 51 rated food grade adhesive to produce a solution of not less than 100 parts per million chlorine residual. The solution obtained shall be retained for a minimum of 24 hours at which time a residual of 10 parts per million or greater must still be present at any point along the line. This method is not recommended if trench water or foreign material has entered the main or if the water temperature is below 5°C (41°F).

Minimum number of 5-g hypochlorite tablets required for a dose of 100 mg/l per 20' of pipe¹

Diameter of Pipe (in.)	2"	4"	6"	8"	12"	16"
Number of Tablets	2	2	4	6	14	28

¹Based on 3¼ grams available chlorine per tablet

Granular chlorine may be allowed only as approved by SPRWS. Minimum volume of hypochlorite granules required for a dose of 100 mg/l per 20' of pipe¹

Diameter of Pipe (in.)	4"	6"	8"	12"	16"	20"	24"	30"
Volume of Granules	1½ tsp	4 tsp	⅛ C	⅓ C	½ C	1 C	1½ C	2⅛ C

5200 FLUSHING THE MAIN

5210 FLUSHING MAINS AFTER CHLORINATION

Contractor shall flush the water mains after chlorination has been completed by opening hydrants, blow-offs and/or temporary discharge assemblies. (See 4780.) This shall include flushing all branches, laterals and large service stubs 4-inches and greater. Post-chlorination flushing shall achieve a minimum scour velocity goal is 2.5 feet per second. A higher velocity would be ideal. The-resulting water shall be dechlorinated and discharged to a suitable location, in accordance with local, state, and federal requirements. . A total turnover of 5-10 pipe volumes should be sufficient. This is equal to 30-60 minutes for 1000 feet of 8” pipe. When flushing is complete, a water sample should be collected from the main and a chlorine residual reading obtained and documented. If the residual is over 4ppm, additional flushing is required.

Contractor shall supply all hoses and fittings necessary when flushing the water main, a SPRWS inspector must be present.

5220 DECHLORINATION

Water expelled during any flushing procedure must be dechlorinated in accordance with the latest revision of ANSI/AWWA C650. Contractor shall provide all hoses and fittings necessary, as well as dechlorination tablets. Contractor shall select a suitable discharge location for water used while flushing, in accordance with local, state, and federal requirements.

5300 PRESSURE AND HYDROSTATIC TESTS

5310 HYDROSTATIC PRESSURE TEST – MAINS AND D.I. SERVICE CONNECTIONS

Newly laid pipe shall be subjected to a hydrostatic pressure of 150 psi or 50% over static pressure, whichever is greater, for a period of 120 minutes. This period begins after the pressure is stabilized. Each valved section of water main shall be tested independently. Only tested and approved sections of water main may be connected to the existing distribution piping. Subjecting existing water mains, fittings or valves to full test pressures is prohibited. Pressure tests shall be performed in conformance with the latest revision of ANSI/AWWA C600. No service connection taps will be permitted until the hydrostatic pressure test and the bacteriological test have been approved. Where it is necessary to test existing mains, a pressure not exceeding 100 psi shall be established at the lowest point of elevation. *No service connection taps will be permitted until the hydrostatic pressure test, the bacteriological test, and conductivity test have been approved.*

5320 HYDROSTATIC PRESSURE TEST – COPPER MAINS AND SERVICE CONNECTIONS

After the service connection has been laid and partially backfilled, the entire length of the service connection shall be subjected to a hydrostatic pressure of 150 psi or 50% over static pressure, whichever is greater, for a 10-minute period. No loss of pressure will be permitted. After the hydrostatic pressure test has been approved and the corporation is turned on, the nut on the corporation shall be tightened down. Caution must be used to avoid over tightening of the nut on the corporation to avoid damaging the corporation body. The corporation shall not be disturbed after final tightening of the nut. The entire length of the service connection, for pressure testing purposes, shall be interpreted as:

- Copper services - from the corporation to the property line or easement line
- Ductile iron services - from the service connection valve to the property line or easement line

With prior approval and at the discretion of SPRWS inspector, a visual inspection on copper services may be accepted if all joints are visible and accessible.

5330 PROCEDURE

The specified test pressure of each valved section, as measured at the lowest available point of elevation, shall be applied by means of a pump connection to the pipe through an air vent or a blow-off in a satisfactory manner. A pump connection to a hydrant will be permitted if an air vent or blow-off is not available. Contractor shall furnish all necessary labor, material and apparatus, including pump, pipe connections, gauges, meters and required measuring devices for conducting the tests. Gauges used for pressure testing mains and services shall display the pressure in 2 psi maximum increments, shall be liquid filled, and shall be approved by SPRWS inspector. It is required that the chlorination flushing (see **Section 5100**) be completed prior to beginning the hydrostatic pressure test for mains and ductile iron services.

5340 EXAMINATION UNDER PRESSURE

Joints that cannot be pressure tested shall be left uncovered until city pressure is applied. Each joint will then be carefully examined for any leaks that might occur. Joints showing visible leaks shall be retightened or regasketed until watertight. Any cracked or defective pipes, fittings, valves or hydrants discovered in consequence of this pressure test shall be removed and replaced by Contractor with sound material and the test shall be repeated until satisfactory to SPRWS Inspector.

5350 HYDROSTATIC TEST

The hydrostatic test shall be performed in accordance with the latest revision of ANSI/AWWA C600, except that the allowable leakage volume shall be 33 percent of that allowed in ANSI/AWWA C600, as reflected in the formula and table below.

Testing allowance is defined as the maximum quantity of makeup water that is added into a pipeline or valved section undergoing hydrostatic pressure testing in order to maintain pressure within ±5 psi of the specified test pressure. All visible leaks are to be repaired regardless of the allowance used for testing.

Contractor shall furnish the gauge and measuring device for the hydrostatic test. Contractor shall furnish the pump, pipe, connections, and all other necessary apparatus, and shall furnish all necessary assistance to conduct the test. The duration of each hydrostatic test shall be 120 minutes. During the test, pipe shall be subject to a pressure of 150 psi or 50% over static pressure, whichever is greater.

No pipe installation will be accepted until the leakage is less than the number of gallons per hour determined by the following formula:

$$L = \left(\frac{SD\sqrt{P}}{148,000} \right) \times .33$$

- Where: L = Testing allowance (makeup water), in gallons per hour
 S = length of pipe tested, in feet
 D = nominal diameter of the pipe, in inches
 P = average test pressure during the hydrostatic test, in psi

Table of Allowable Leakage

Allowable Leakage (L) per 2 hours
 Per 100 feet @ P (150 psi)

Pipe Size (D)	Gallons	Ounces
4"	0.010	<u>1.28</u>
6"	0.017	<u>2.18</u>
8"	0.022	<u>2.82</u>
12"	0.033	<u>4.22</u>
16"	0.044	<u>5.63</u>
20"	0.055	<u>7.04</u>
24"	0.066	<u>8.45</u>
30"	0.083	<u>10.62</u>

5360 VARIATION FROM PERMISSIBLE LEAKAGE

Should any test of pipe disclose leakage greater than that specified in **Section 5350**, Contractor shall, at its own expense, locate and repair the defective joints or materials until the leakage is within the specified allowance.

5400 BACTERIOLOGICAL TESTS

After flushing is complete, each section of main will be shut down for a period of 16 hours. Samples of water shall then be drawn for bacteriological evaluation by SPRWS Inspector. All samples shall be taken every 200 feet, in accordance with AWWA C651. Following the initial sample collection, the sampling tap shall be run for a period of 15 minutes at which point another set of samples (one every 200 feet) will be collected. Both sets of samples must pass bacteriological testing. No main shall be placed in service until a passing result is achieved. All samples will be tested by the SPRWS laboratory. No third-party testing results will be accepted by SPRWS in determining a passing condition.

In the event of a failure of any single sample collected during this procedure, additional flushing (including bi-directional flushing if possible), chlorination, pigging may be required to prepare for another round of the testing procedure.

Contractor shall provide all hoses and fittings necessary to connect to a 3" or larger, male cam lock, as well as dechlorination tablets. Contractor shall select a suitable discharge location for water used while testing & flushing in accordance with local, state, and federal requirements.

5500 ELECTRICAL CONDUCTIVITY TEST

Electrical conductivity tests on iron pipe shall be performed by Contractor and approved by SPRWS Inspector. After the backfilling is complete and the lines are hydrostatically tested and approved, an electrical test shall be conducted through all joints to verify that adequate conductivity is maintained through the joint to permit the use of thawing equipment. This test shall be made with a thawing machine or arc welder having the necessary volt meters and amp meters to indicate the results of the test. The test shall run 5 minutes with a minimum 300 ampere current at a maximum of 30 volts. The main must be filled with water and the air expelled before the electrical test can be performed. Conductivity tests shall be permitted only after the hydrostatic pressure test has been approved.

5600 CATHODIC PROTECTION SYSTEM TESTING

Cathodic protection systems shall be subject to testing. The contractor shall be responsible for correcting all deficiencies due to improper installation and defective equipment, in addition to performing any re-testing required.

Exothermic welds shall be tested by the contractor for adherence to the pipe and for electrical continuity between the pipe and wires.

A negative potential of at least 850 millivolts or greater (more negative) shall be measured with the cathodic protection system applied. This potential is measured with the positive lead of a voltmeter connected to the wire attached to the pipe and the negative lead attached to a saturated copper-copper sulfate reference electrode contacting electrolyte.

A minimum of 100 millivolts of cathodic polarization shift shall be measured between the structure surface and a stable reference electrode contacting the electrolyte. The formation or decay of polarization can be measured to satisfy this criterion.

5700 INSPECTIONS

Initial Inspection

Where existing water facilities are situated within the project area, see Initial Inspection in **Section 4110**.

Interim Inspection

Contractor shall provide SPRWS with no less than 3-days' notice prior to placing the wearing course. Following notice, SPRWS Inspector will perform an interim inspection of valve boxes to ensure they are at proper grade prior to placement of the wearing course and will provide Contractor with a list of valve boxes not at proper grade or otherwise deficient. Contractor shall repair or adjust listed valve boxes to proper grade prior to placement of wearing course.

Final Inspection

After the mains have been completely tested and approved, Contractor shall be responsible for preparing the valve boxes, hydrants and service connection boxes for final inspection. Valve nut shall be centered, and gate box shall be plumb. Where the mains have been tested and approved, and after Contractor or its subcontractors have completed final restoration (e.g. turf establishment, roadway surfacing), Contractor shall adjust to final grade and make suitable for final inspection valve boxes, service connection boxes, hydrants and appurtenances impacted by the project.

After Contractor has made all water facilities suitable for final inspection, Contractor shall schedule a joint inspection of all water facilities within the project with SPRWS Inspector. From this inspection, SPRWS will provide Contractor with a deficiency list showing water facilities Contractor is responsible to repair, replace or adjust. Contractor shall schedule the final inspection and complete listed repairs, replacements and adjustments in a timely manner.

5800 AS-BUILT DRAWINGS

Engineer shall provide SPRWS with a complete set of as-built drawings in hard copy and electronic format within two months of completion of pipe installation.

Electronic format shall be in accordance with current industry standards in AutoCAD or ESRI GIS format (plan view only in GIS), as may be determined appropriate by SPRWS. AutoCAD drawings shall include any customized Plot Style Tables (.ctb or .stb) or line types (.lin) and shall not require links to other drawings. Any changes in approved plans must be resubmitted for review and approval. As-built drawings must show both plan and profile views of

constructed facilities. Fittings shall be identified and located by station or other suitable dimensions.

- END OF DIVISION 5000 -

Drawing Index

Standard Plate D-1	Typical Intersection
Standard Plate D-2	Valve Box & Installation
Standard Plate D-3	Hydrant Installation
Standard Plate D-4	Saint Paul Standard Thread Hydrant Nozzle
Standard Plate D-5	Water Main Trench Detail
Standard Plate D-6	Typical Casing Pipe Installation
Standard Plate D-7	Air Vent Installation
Standard Plate D-8	Blow-off for 6” and 8” Mains
Standard Plate D-9	Blow-off for 12” and Larger Mains
Standard Plate D-10	Typical Water Main Offsets
Standard Plate D-11 (1 of 4)	Restrained Pipe Requirement (DIP 4.0’ – 6.0’ Cover)
Standard Plate D-11 (2 of 4)	Restrained Pipe Requirement (DIP 7.0’ – 8.0’ Cover)
Standard Plate D-11 (3 of 4)	Restrained Pipe Requirement (PVC 4.0’ – 6.0’ Cover)
Standard Plate D-11 (4 of 4)	Restrained Pipe Requirement (PVC 7.0’ – 8.0’ Cover)
Standard Plate D-12	Standard Easement Marker
Standard Plate D-13	Typical 1”, 1 ½” and 2” Service and Lawn Sprinkler Installation
Standard Plate D-14	Inset Lid Covers For Sloped Pavement
Standard Plate D-15 (1 of 2)	Cathodic Protection Anode and Test Station Installation
Standard Plate D-15 (2 of 2)	Cathodic Protection Magnesium Anode Placement

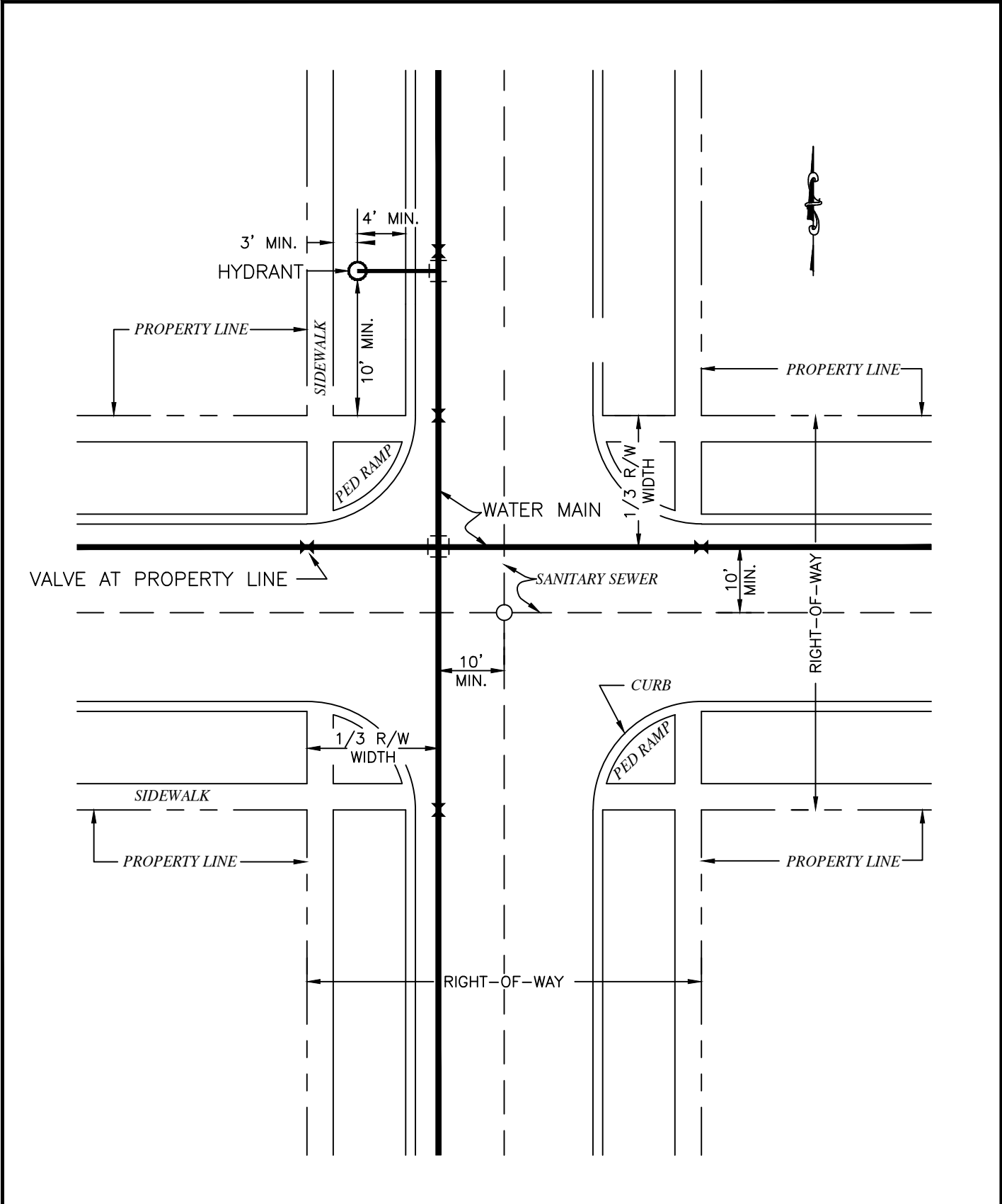

DR. *AMB* DATE. 01/13/2020
 CH. *TMJ*
 APPROVED *RWH*

SAINT PAUL REGIONAL WATER SERVICES
 CITY OF ST. PAUL, MN
TYPICAL INTERSECTION

STANDARD
 PLATE
D-1

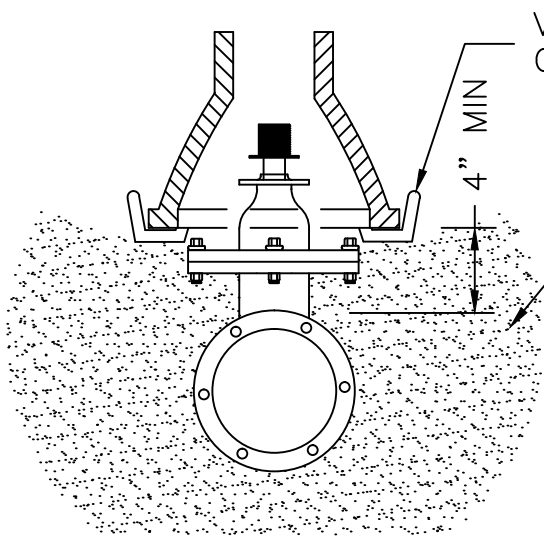

VALVE BOX BASE TO REST ON VALVE BOX ALIGNER

4" MIN

COMPACTED BACKFILL

DETAIL OF BASE SUPPORT

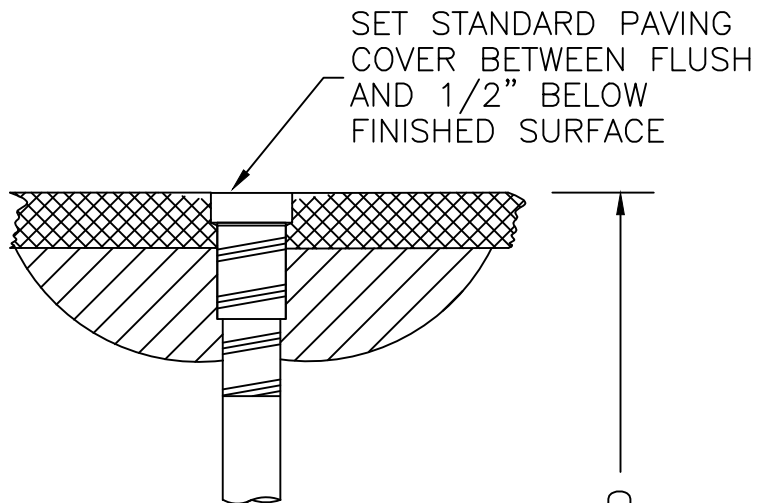

SET STANDARD PAVING COVER BETWEEN FLUSH AND 1/2" BELOW FINISHED SURFACE

AS REQUIRED

GATE VALVE
MECHANICAL JOINT
CLOCKWISE OPENING
CONFORMING TO AWWA C509

VALVE BOX
TYLER SERIES 6860
ITEM G OR APPROVED EQUAL

VALVE BOX ALIGNER

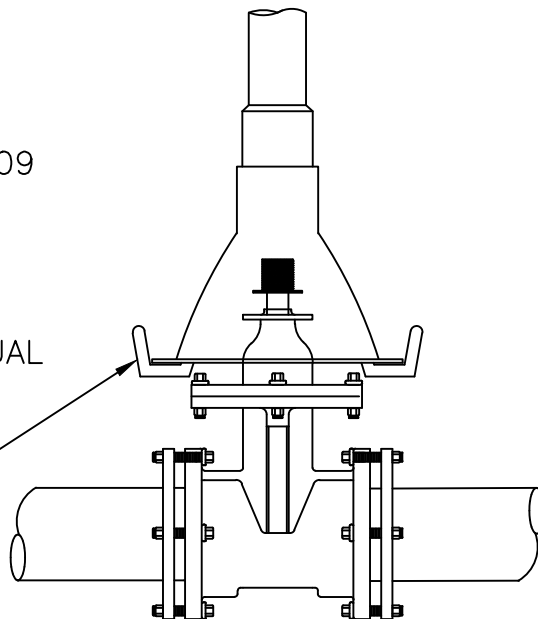

16" PIPES AND LARGER REQUIRE BUTTERFLY VALVES

DR. *LJP* DATE. 01/13/2020
CH. *VLH*
APPROVED *DJS*

SAINT PAUL REGIONAL WATER SERVICES
ST. PAUL, MINNESOTA

STANDARD
PLATE

VALVE BOX & INSTALLATION

D-2

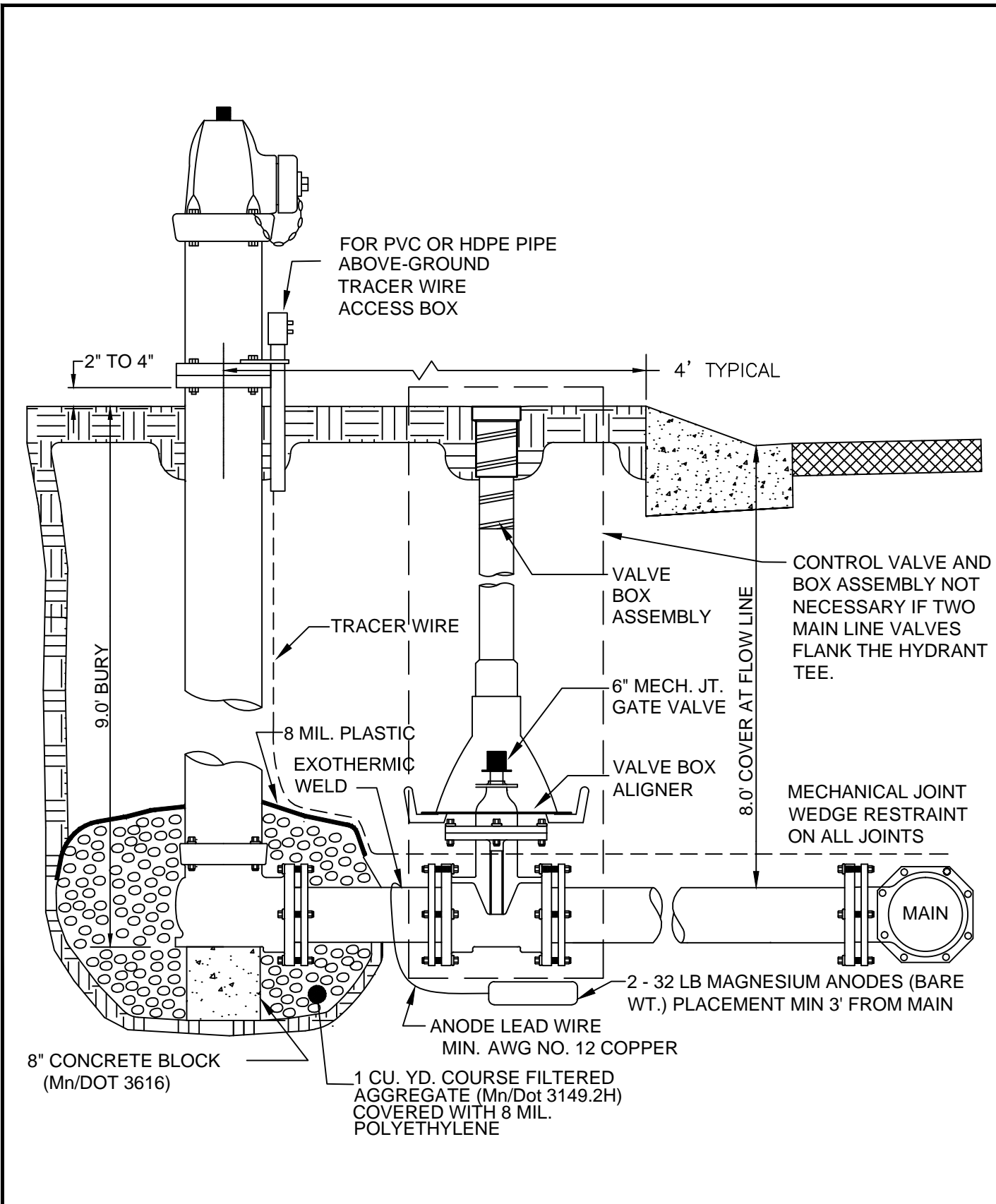

DR. *AMB* DATE. 01/13/2020

CH. *TMJ*

APPROVED *RWH*

SAINT PAUL REGIONAL WATER SERVICES
ST. PAUL, MINNESOTA

HYDRANT INSTALLATION

STANDARD PLATE

D-3

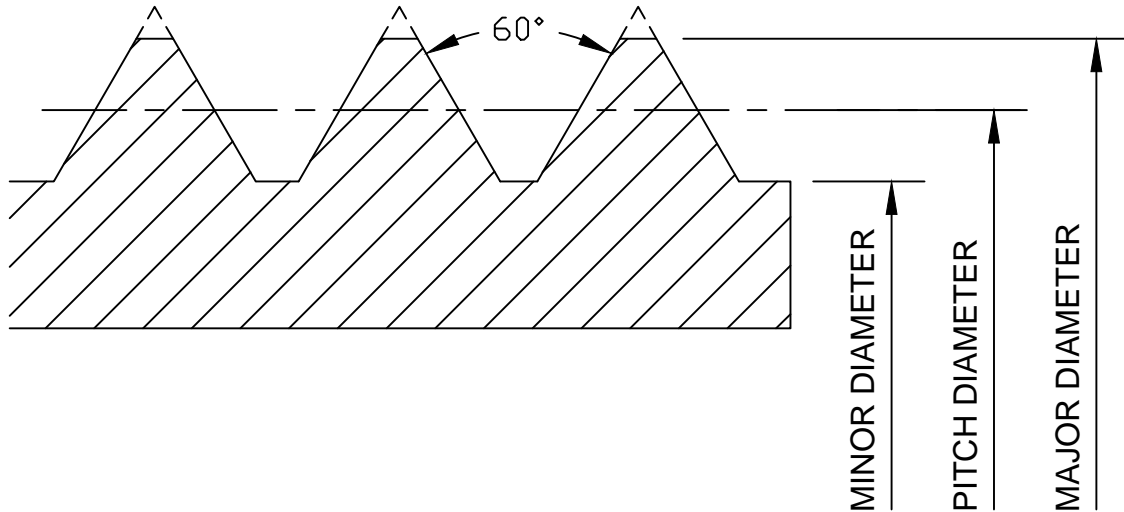

NIPPLE THREAD

Threads Per Inch	6
Nom Major Diameter	5.531
Max Major Diameter	5.541
Min Major Diameter	4.491
Max Pitch Diameter	5.445
Min Pitch Diameter	5.427
Max Minor Diameter	5.337

NOTE: Waterous Company Code No. TP60517 or equivalent

DR. *LJP* DATE. 01/13/2020
 CH. *MGA*
 APPROVED
DJS

SAINT PAUL REGIONAL WATER SERVICES
 CITY OF ST. PAUL, MN

SAINT PAUL STANDARD THREAD

STANDARD
 PLATE

D-4

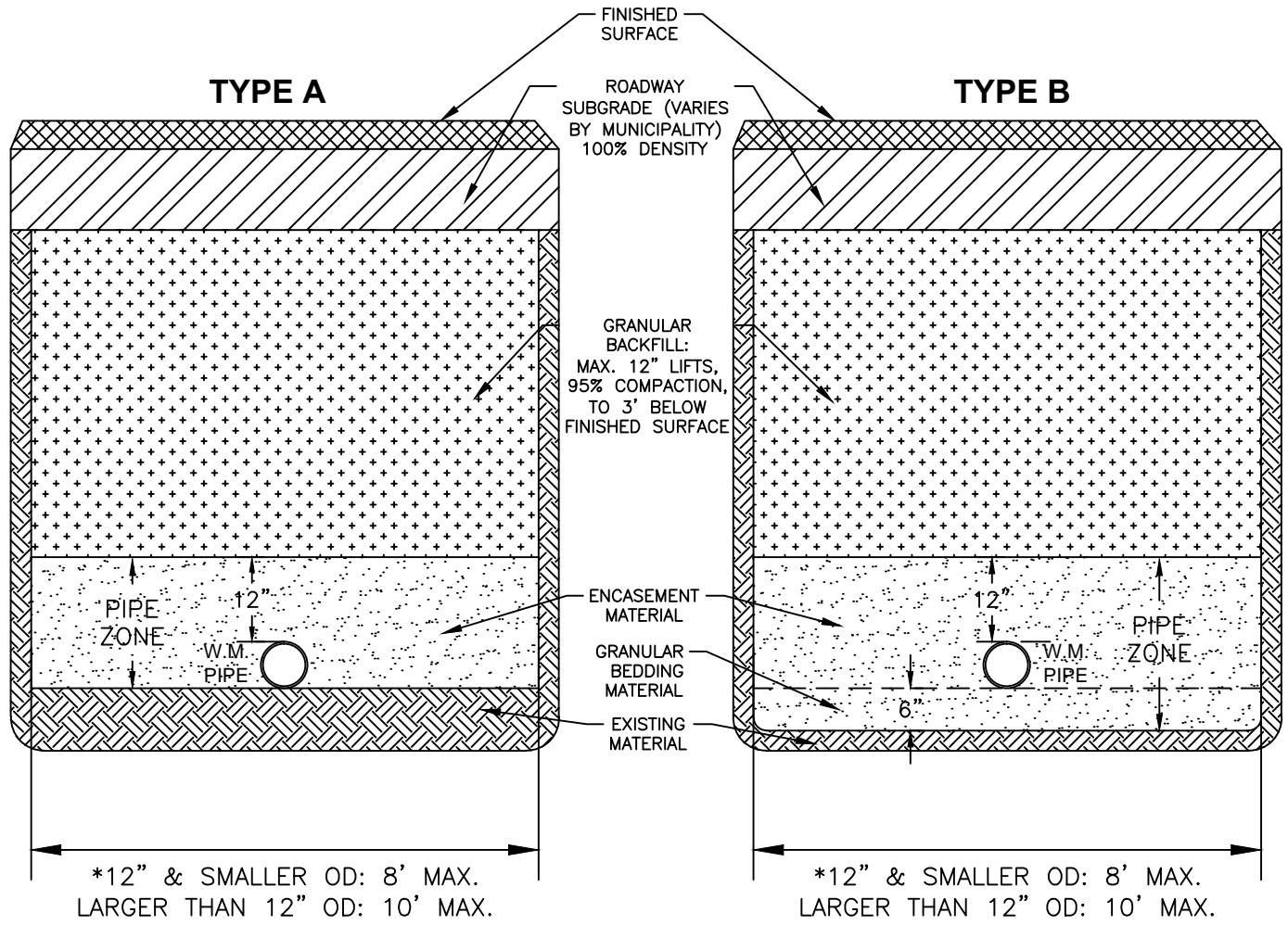

TYPE A TRENCH TO BE CONSIDERED STANDARD TRENCH

TYPE B TRENCH TO BE IMPLEMENTED IN THE FOLLOWING CASES:

- BASE MATERIAL IS OR CONTAINS ROCK(S)
- WET CONDITIONS
- FLEXIBLE PIPE (HDPE, PEX, PVC, ETC.)
- UNSUITABLE/UNSTABLE SOILS

SPRWS TO MAKE FINAL DETERMINATION TRENCH TYPE AND USE OF IMPORTED BEDDING AND BACKFILL MATERIAL

* TRENCH WIDTH INCLUDING TENCH BOX

DR. *AMB* DATE. 02/05/2020

CH. *TMJ*

APPROVED

RWH

SAINT PAUL REGIONAL WATER SERVICES
CITY OF ST. PAUL, MN

WATER MAIN TRENCH DETAIL

STANDARD
PLATE

D-5

TYPICAL HIGHWAY OR STREET CROSSING

TYPICAL RAILWAY CROSSING

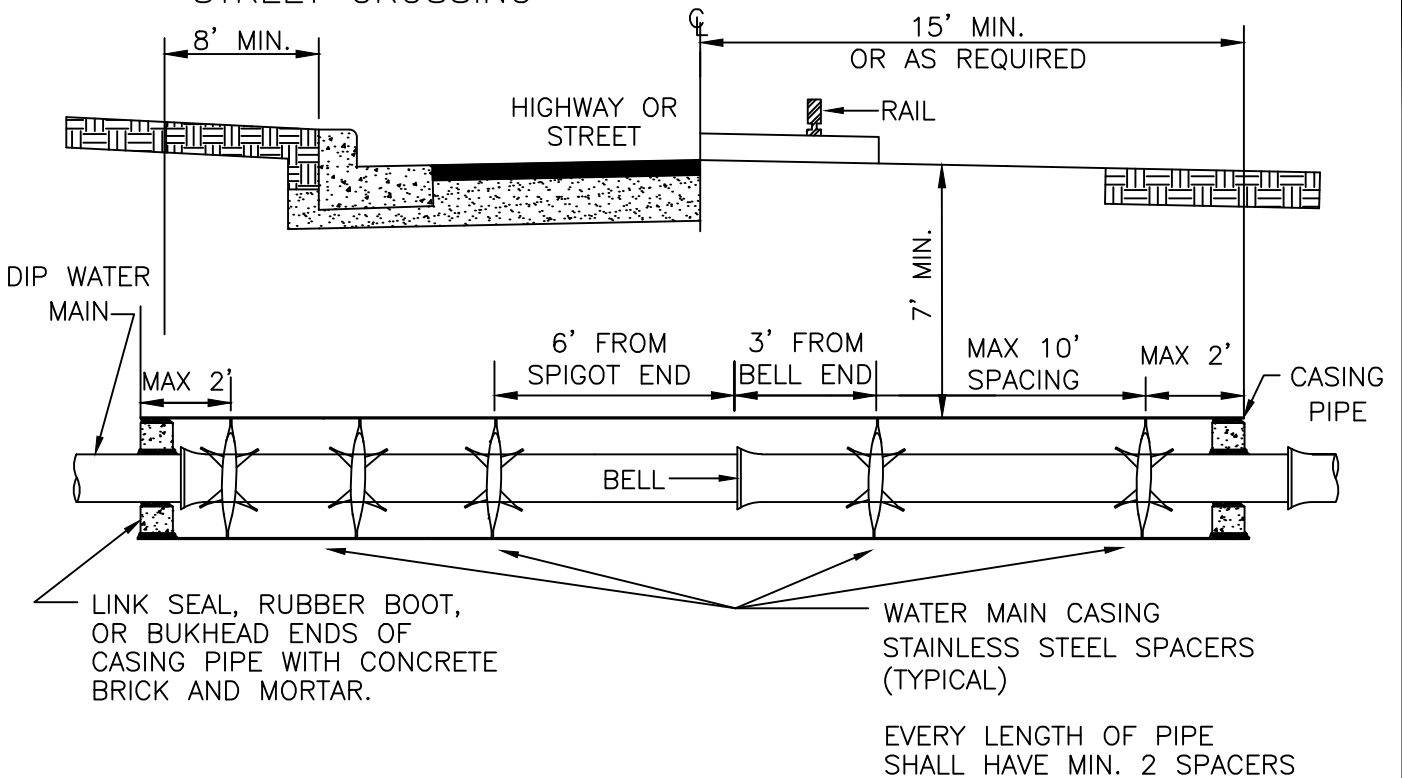

BELL O.D. (MJ PIPE)	SIZE OF MAIN	MINIMUM CASING SIZE	MINIMUM CASING WALL THICKNESS
11.12"	6"	18"	0.250"
13.37"	8"	20"	0.250"
17.88"	12"	24"	0.250"
22.50"	16"	30"	0.375"
27.00"	20"	36"	0.500"
31.50"	24"	42"	0.500"

- CASING SPACERS ARE REQUIRED ON WATER MAIN AND SHALL BE INCIDENTAL TO CASING UNLESS OTHERWISE SPECIFIED.
- ALL WATER MAIN IN CASING PIPE SHALL BE APPROVED RESTRAINED JOINT.
- CASING PIPE TO BE WELDED STEEL WITH A MINIMUM YIELD OF 35,000 PSI. WALL THICKNESS AND SHALL BE AS DESIGNATED BY THE PERMITTING AUTHORITY. IN NO CASE SHALL THE CASING PIPE WALL THICKNESS BE LESS THAN 0.25". STEEL CASING PIPE SHALL BE COATED INSIDE AND OUT WITH AT MINIMUM, A BITUMINOUS ASPHALT COATING.
- CASING SPACERS SHALL BE STAINLESS STEEL AS MANUFACTURED BY CASCADE WATERWORKS MFG., ADVANCED PRODUCTS & SYSTEMS, INC. OR APPROVED EQUAL.

DR. *AMB* DATE. 01/13/2020

CH. *TMJ*

APPROVED

RWH

SAINT PAUL REGIONAL WATER SERVICES
CITY OF ST. PAUL, MN

TYPICAL CASING PIPE INSTALLATION

STANDARD
PLATE

D-6

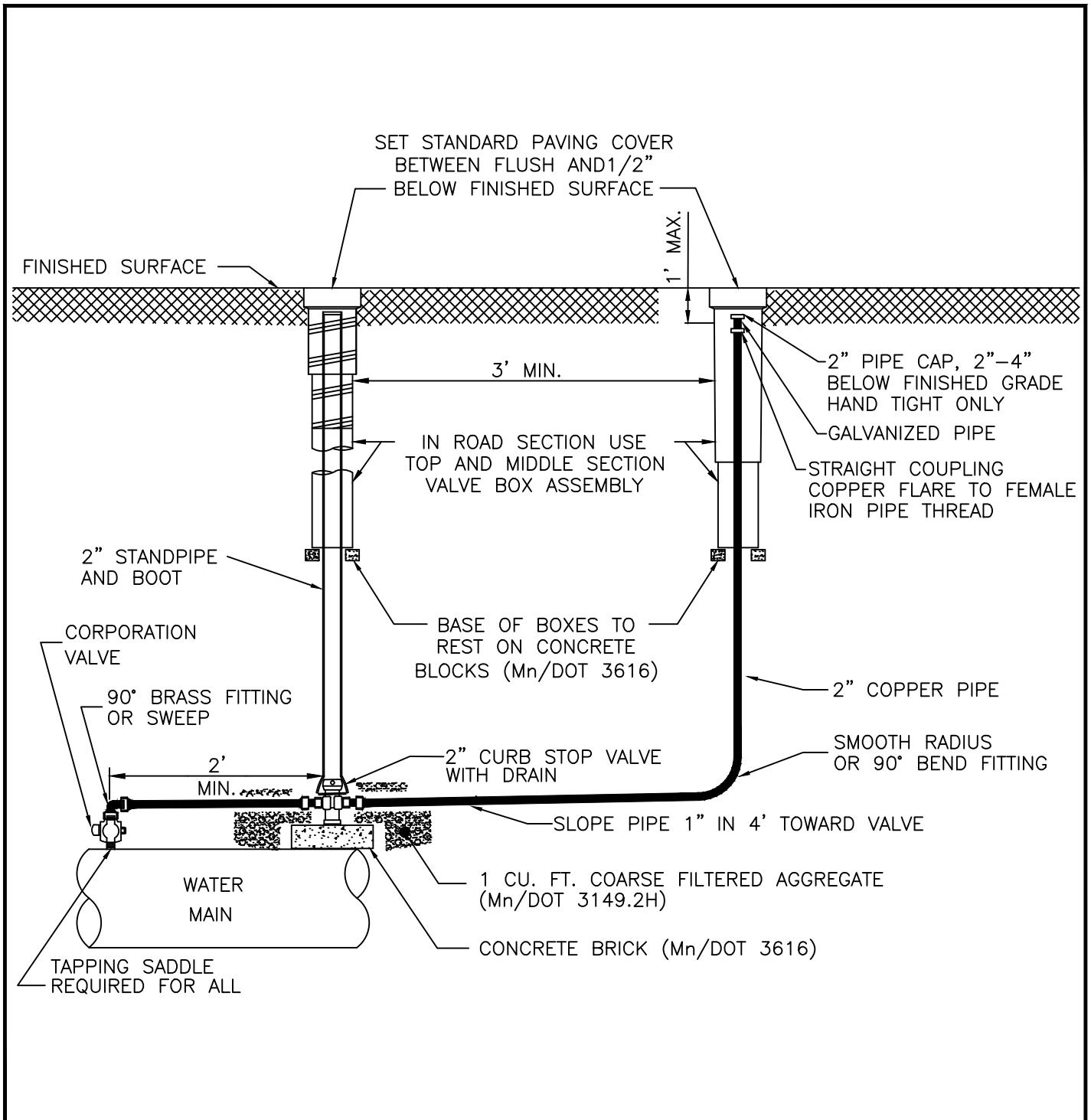

CURB STOP VALVE MUST BE APPROVED DRAINING VALVE
SEE SECTION 3310

DR. <i>AMB</i> DATE. 01/13/2020 CH. <i>TMJ</i>	SAINT PAUL REGIONAL WATER SERVICES ST. PAUL, MINNESOTA	STANDARD PLATE
APPROVED <i>DJS</i>		AIR VENT INSTALLATION

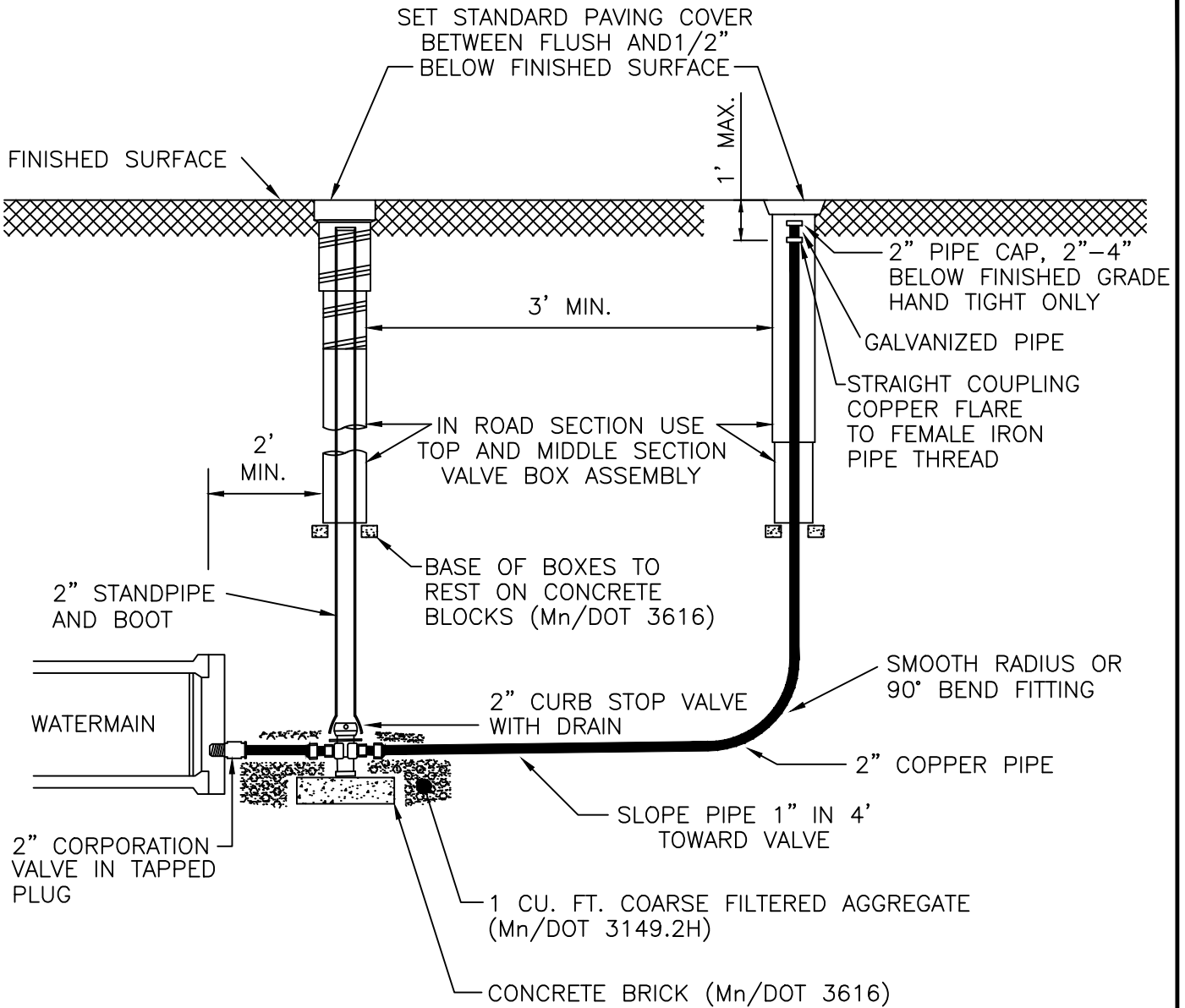

CURB STOP VALVE MUST BE APPROVED DRAINING VALVE PER SECTION 3310

DR. *AMB* DATE. 01/13/2020

CH. *TMJ*

APPROVED

RWH

SAINT PAUL REGIONAL WATER SERVICES
CITY OF ST. PAUL, MN

BLOW-OFF FOR 6" & 8" MAINS

STANDARD
PLATE

D-8

SET STANDARD MANHOLE COVER
BETWEEN FLUSH AND 1/2" BELOW
FINISHED SURFACE (TYPICAL)

"WATER" SHALL BE PERMANENTLY
MARKED ON THE TOP OF COVER

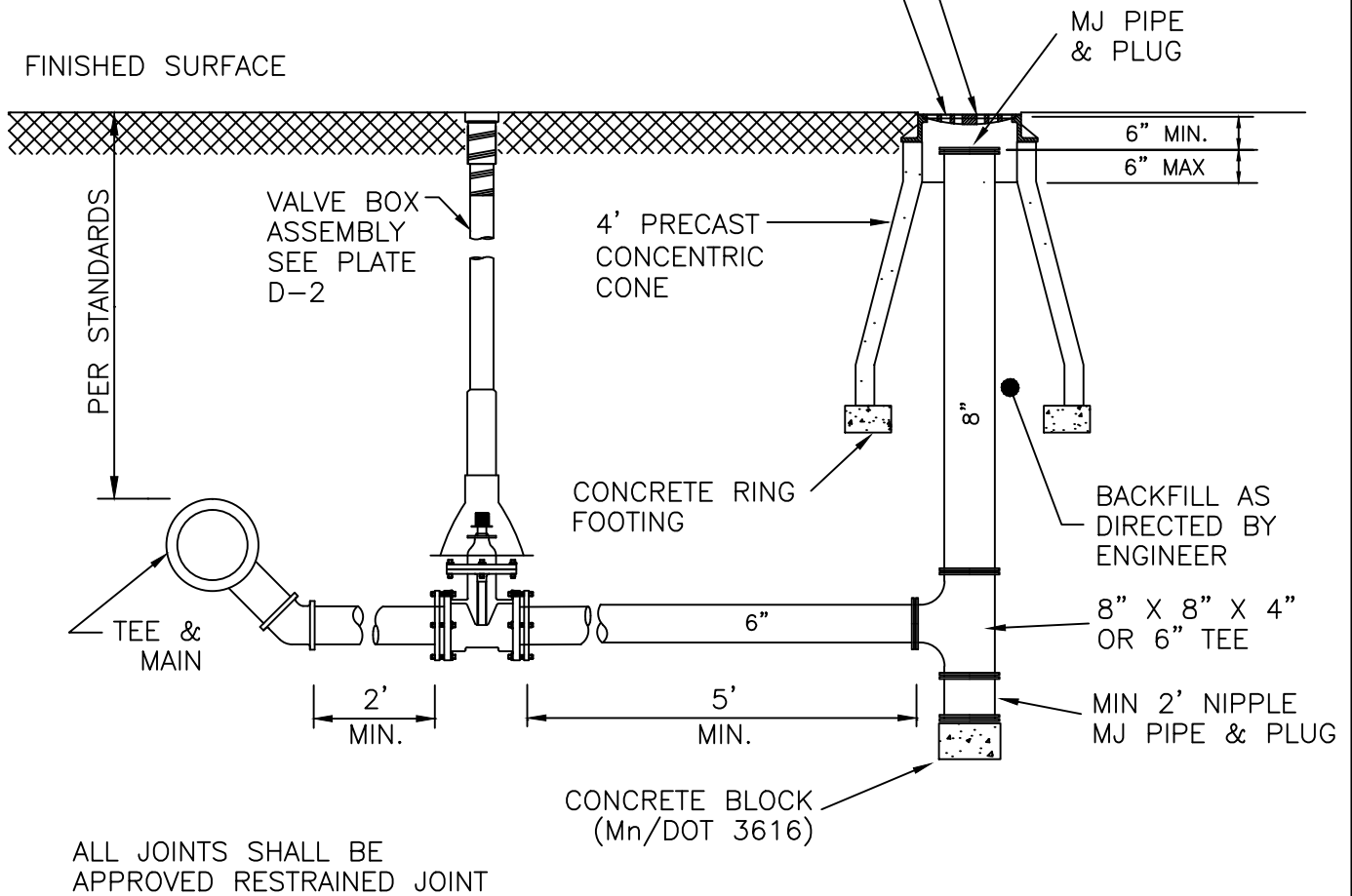

DR. *LJP* DATE. *DJS*

CH. *VLM*

APPROVED

DJS

SAINT PAUL REGIONAL WATER SERVICES
CITY OF ST. PAUL, MN

BLOW-OFF FOR 12" & LARGER MAINS

STANDARD
PLATE

D-9

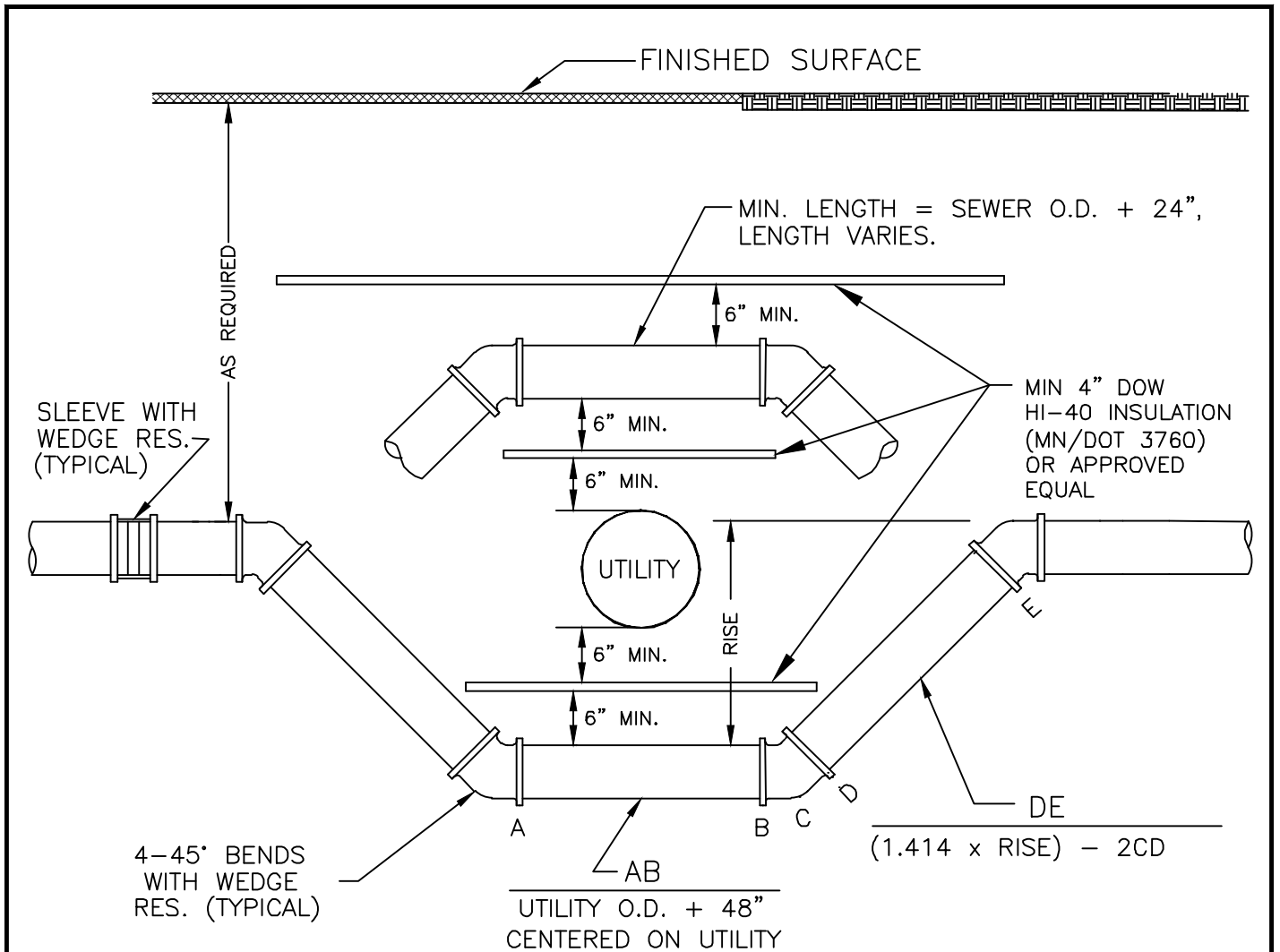

- IF AB IS LONGER THAN A STANDARD LENGTH OF PIPE, NO SLIP JOINT WILL BE ALLOWED.
- ALL OFFSETS SHALL BE RESTRAINED

WM SIZE	CD (STD. CIP)	CD (COMPACT DIP)
6"	5"	3"
8"	5.5"	3.5"
12"	7.5"	5.5"
16"	8"	5.5"

FOR RESTRAINED PIPE LENGTHS SEE PLATE D-11

* INSULATION AND MIN. SEPARATION SHOWN BETWEEN WATER MAIN AND UTILITY APPLY TO STORM SEWER CROSSINGS ONLY. SEE SECTION 4570 FOR SEPARATION REQUIREMENTS FOR OTHER UTILITY CROSSINGS.

DUCTILE IRON PIPE (DIP) WRAPPED IN POLYETHYLENE

MINIMUM FEET OF RESTRAINED PIPE REQUIRED

PIPE SIZE	4.0' COVER				5.0' COVER				6.0' COVER			
	22.5°	45°	90°	DEAD END	22.5°	45°	90°	DEAD END	22.5°	45°	90°	DEAD END
4"					3	4	14	40	3	5	12	33
6"					4	8	20	56	4	7	17	47
8"					5	11	26	73	5	9	22	62
12"					8	15	36	104	6	13	30	88
16"	11	23	56	164	10	19	46	134	8	16	39	114
20"	14	28	67	199	11	23	55	164	10	20	47	139
24"	16	32	77	232	13	27	64	192	11	23	55	164
30"	19	38	92	280	16	32	77	232	14	28	66	199
36"	21	44	105	325	18	37	89	271	16	32	77	233
42"	24	49	117	367	20	42	100	307	18	36	87	265
48"	24	54	129	407	22	46	110	343	20	40	96	296

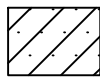

NOT ALLOWED

THE TABLE WAS DEVELOPED FROM CRITERIA IDENTIFIED IN THE *EBBA IRON INC.* RESTRAINED LENGTH CALCULATOR. THE TABLE ASSUMES 150 PSI, MH. GRANULAR SOILS AND TYPE 4 TRENCH CONDITIONS. FOR REDUCERS AND TEES REFER TO THE LENGTH CALCULATOR. [HTTPS://EBAA.COM/CALCULATOR](https://ebaa.com/calculator). USE A SAFETY FACTOR OF 1.5 TO 1.

DR. <i>AMB</i> DATE. 01/13/2020 CH. <i>TMJ</i> APPROVED <div style="text-align: right; font-size: 1.2em; font-weight: bold;"><i>RWH</i></div>	SAINT PAUL REGIONAL WATER SERVICES CITY OF ST. PAUL, MN RESTRAINED PIPE REQUIREMENT DIP 4.0' - 6.0' EARTH COVER	STANDARD PLATE D-11 1 of 4
--	--	--

DUCTILE IRON PIPE (DIP) WRAPPED IN POLYETHYLENE

MINIMUM FEET OF RESTRAINED PIPE REQUIRED

PIPE SIZE	7.0' COVER				8.0' COVER			
	22.5°	45°	90°	DEAD END	22.5°	45°	90°	DEAD END
4"	2	5	10	29	2	4	9	25
6"	3	6	14	41	3	6	13	36
8"	4	8	19	53	4	7	17	47
12"	6	11	26	76	5	10	23	67
16"	7	14	34	99	6	13	30	87
20"	9	17	41	121	8	16	37	107
24"	10	20	48	142	9	18	43	126
30"	12	24	58	173	11	22	52	154
36"	14	28	68	204	12	25	61	181
42"	16	32	77	232	14	29	69	207
48"	17	36	85	261	16	32	77	233

THE TABLE WAS DEVELOPED FROM CRITERIA IDENTIFIED IN THE
EBBA IRON INC. RESTRAINED LENGTH CALCULATOR.
THE TABLE ASSUMES 150 PSI, MH. GRANULAR SOILS AND TYPE 4

DR. *AMB* DATE. 01/13/2020

CH. *TMJ*

APPROVED

RWH

SAINT PAUL REGIONAL WATER SERVICES
CITY OF ST. PAUL, MN

RESTRAINED PIPE REQUIREMENT
DIP 7.0' - 8.0' EARTH COVER

STANDARD
PLATE

D-11
2 of 4

PVCO PIPE

MINIMUM FEET OF RESTRAINED PIPE REQUIRED

PIPE SIZE	4.0' COVER				5.0' COVER				6.0' COVER			
	22.5°	45°	90°	DEAD END	22.5°	45°	90°	DEAD END	22.5°	45°	90°	DEAD END
4"					3	5	12	26	2	4	10	21
6"					4	7	17	36	3	6	14	30
8"					5	9	22	47	4	8	18	40
12"					6	13	30	67	5	11	26	56
16"	10	20	47	106	8	16	39	87	7	14	33	73
20"	12	24	57	129	10	20	47	106	8	17	40	90
24"	13	28	66	151	11	23	55	124	10	20	47	105
30"	16	33	78	182	13	27	65	150	12	24	56	128



NOT ALLOWED

THE TABLE WAS DEVELOPED FROM CRITERIA IDENTIFIED IN THE **EBBA IRON INC.** RESTRAINED LENGTH CALCULATOR. THE TABLE ASSUMES 150 PSI, MH. GRANULAR SOILS AND TYPE 4 TRENCH CONDITIONS. FOR REDUCERS AND TEES REFER TO THE LENGTH CALCULATOR. [HTTPS://EBAA.COM/CALCULATOR](https://ebaa.com/calculator). USE A SAFETY FACTOR OF 1.5 TO 1.

DR. *AMB* DATE. 01/13/2020
 CH. *TMJ*
 APPROVED
RWH

SAINT PAUL REGIONAL WATER SERVICES
 CITY OF ST. PAUL, MN
RESTRAINED PIPE REQUIREMENTS
 PVCO PIPE 4.0' - 6.0' EARTH COVER

STANDARD
 PLATE
D-11
 3 of 4

PVCO PIPE

MINIMUM FEET OF RESTRAINED PIPE REQUIRED

PIPE SIZE	7.0' COVER				8.0' COVER			
	22.5°	45°	90°	DEAD END	22.5°	45°	90°	DEAD END
4"	2	4	9	19	2	3	8	16
6"	3	5	12	26	3	5	11	23
8"	4	7	16	34	3	6	14	30
12"	5	10	22	49	4	8	20	43
16"	6	12	29	63	5	11	25	56
20"	7	15	35	78	7	13	31	68
24"	9	17	41	91	8	15	36	81
30"	10	21	49	111	9	18	44	98

THE TABLE WAS DEVELOPED FROM CRITERIA IDENTIFIED IN THE **EBBA IRON INC.** RESTRAINED LENGTH CALCULATOR. THE TABLE ASSUMES 150 PSI, MH. GRANULAR SOILS AND TYPE 4 TRENCH CONDITIONS. FOR REDUCERS AND TEES REFER TO THE LENGTH CALCULATOR. [HTTPS://EBAA.COM/CALCULATOR](https://ebaa.com/calculator). USE A SAFETY FACTOR OF 1.5 TO 1.

DR. *AMB* DATE. 01/13/2020

CH. *TMJ*

APPROVED

RWH

SAINT PAUL REGIONAL WATER SERVICES
CITY OF ST. PAUL, MN

RESTRAINED PIPE REQUIREMENT
PVCO PIPE 7.0' - 8.0' EARTH COVER

STANDARD
PLATE

D-11
4 of 4

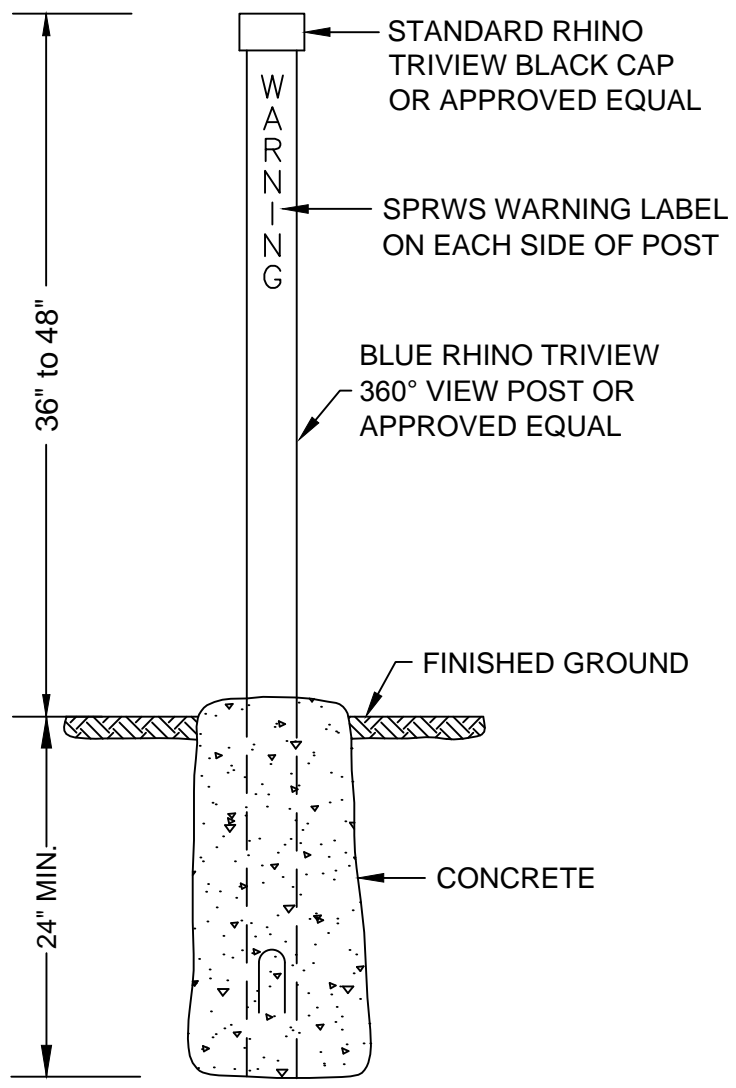

MARKER DETAIL

HEIGHT, MATERIAL, COLOR AND ANCHORING METHOD OF MARKER MAY BE ADJUSTED BY SPRWS INSPECTOR AS FIELD CONDITIONS REQUIRE

SEE SECTION 2220-5 FOR MORE INFORMATION ON MARKER REQUIREMENTS

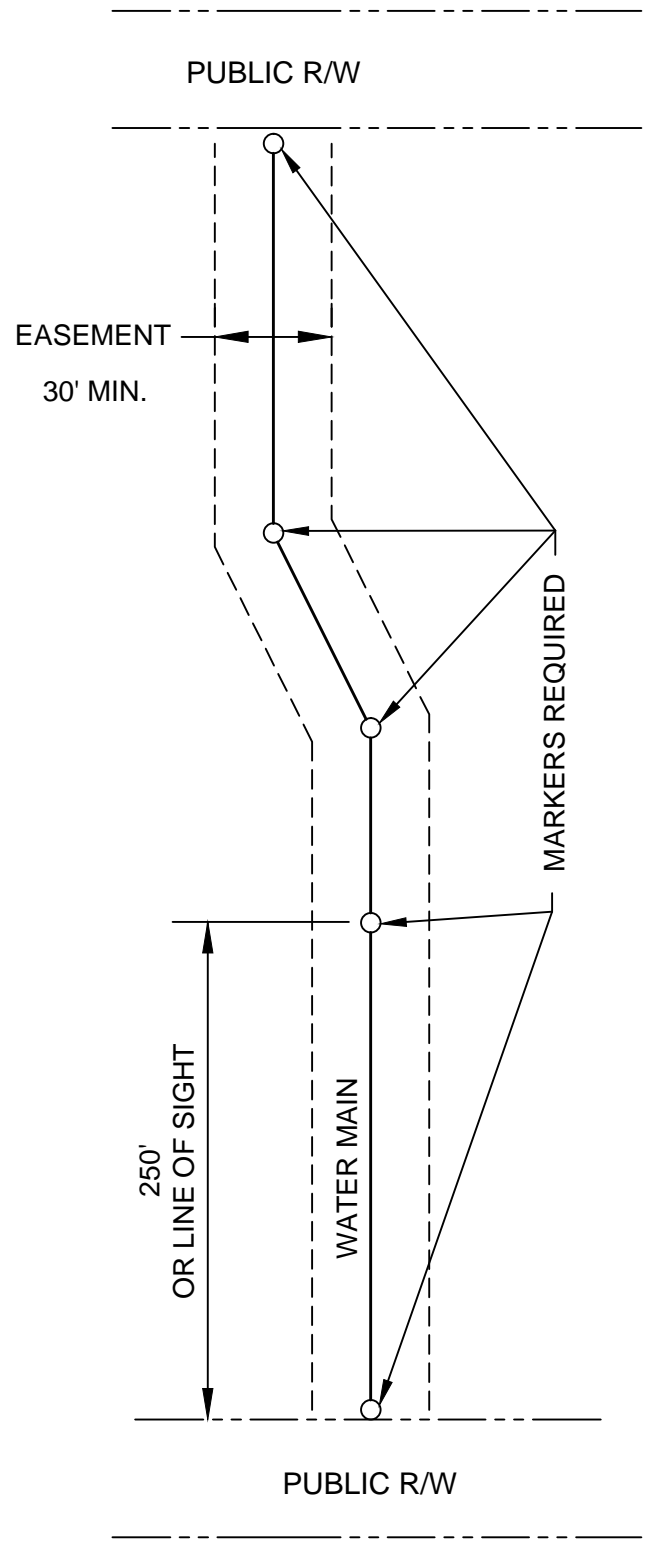

TYPICAL LOCATION

DR. *LJP* DATE. 01/13/2020
 CH. *VLH*
 APPROVED *DJS*

SAINT PAUL REGIONAL WATER SERVICES
 CITY OF ST. PAUL, MN

STANDARD EASEMENT MARKER

STANDARD
 PLATE

D-12

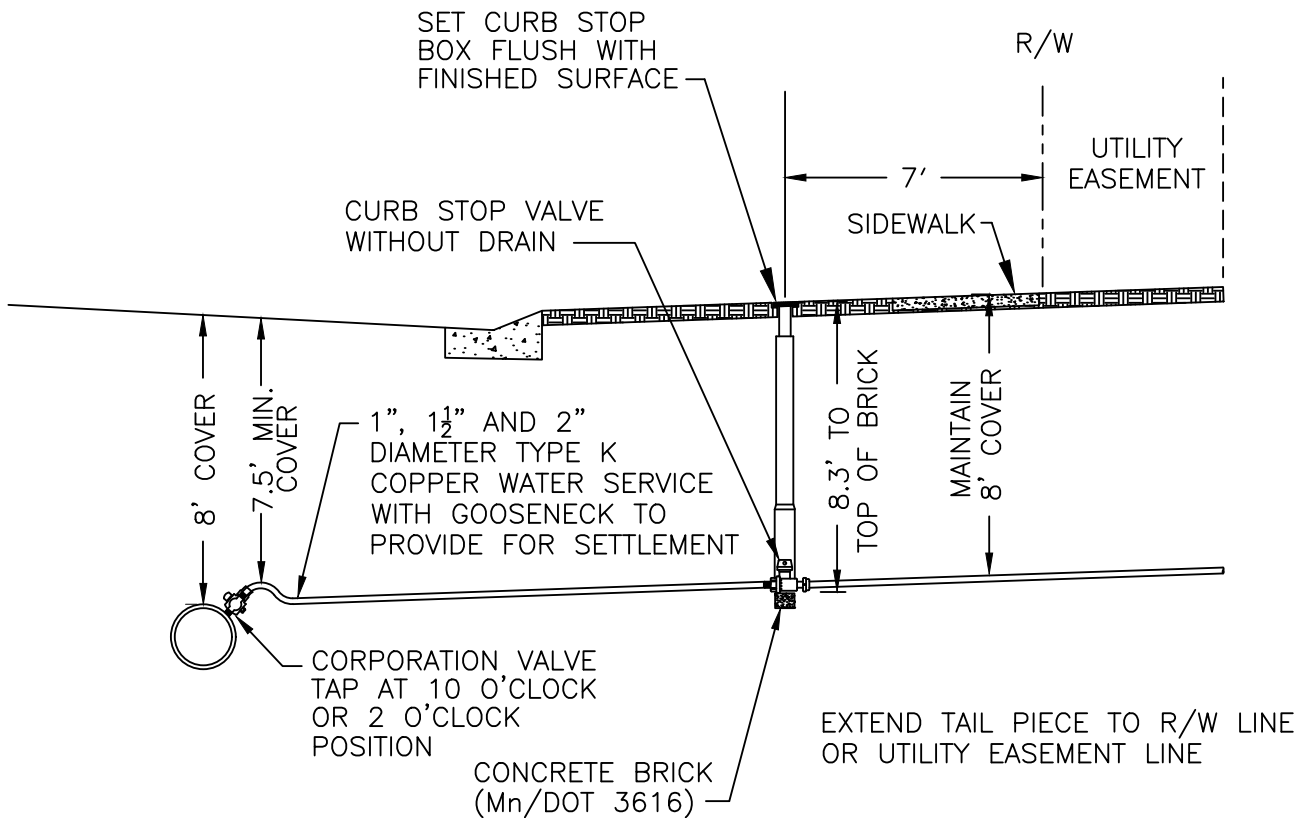

REFER TO SECTION 3300 FOR ADDITIONAL REQUIREMENTS

LIQUID TEFLON OR TEFLON TAPE REQUIRED AT ALL THREADED FITTINGS.

LAWN SPRINKLER

SAME AS SERVICE EXCEPT:

- CURB STOP VALVE WITH DRAIN
- CURB STOP BURIED WITH 2'x2'x2' CLEAN 1 1/2" ROCK WRAPPED IN GEOTEXILE NONWOVEN FABRIC

DR. LJP DATE. 02/03/2023

CH. MGA

APPROVED

DJS

SAINT PAUL REGIONAL WATER SERVICES
CITY OF ST. PAUL, MN

TYPICAL 1", 1-1/2" AND 2" SERVICE
& LAWN SPRINKLER INSTALLATION

STANDARD
PLATE

D-13

C/L

R/W

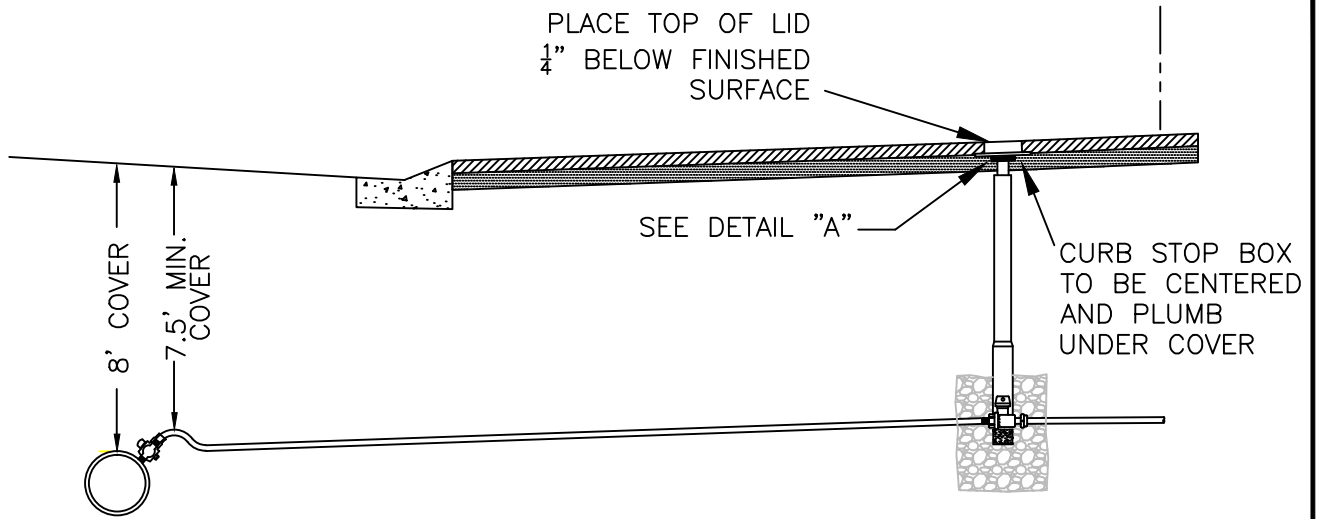

TYPICAL CONCRETE DRIVEWAY

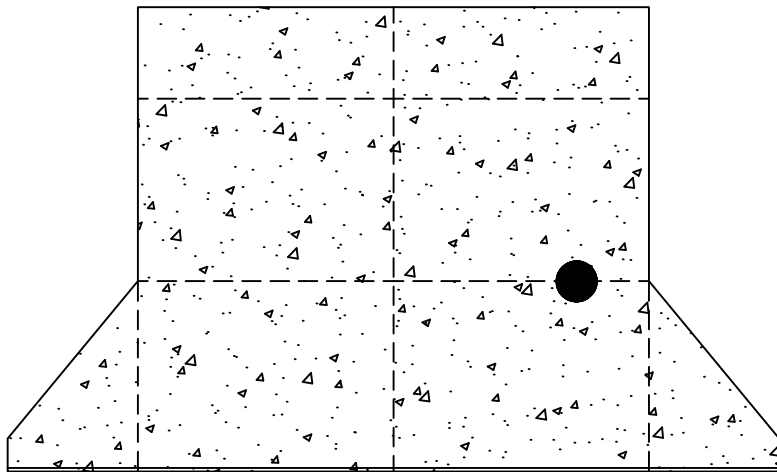

CONTRACTOR TO
INSTALL LID 2" - 4"
ABOVE CURB BOX
(SEE DETAIL "A")

SLOPE OF COVER
TOP TO MATCH
FINISHED GRADE

DETAIL "A"

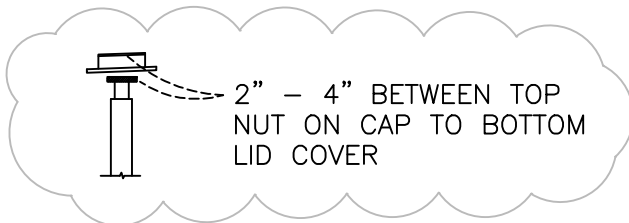

FORD TYPE "A" SINGLE LID
COVER OR APPROVED EQUAL



DR. *LJP* DATE. 01/13/2020

CH. *MGA*

APPROVED

DJS

SAINT PAUL REGIONAL WATER SERVICES
CITY OF ST. PAUL, MN

INSET LID COVER FOR SLOPED PAVEMENT

STANDARD
PLATE

D-14

**STANDARD
ANODE DETAIL**

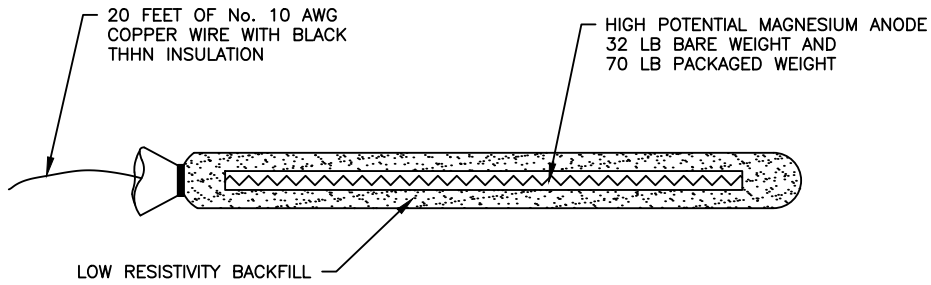

ANODE TEST PANEL CONFIGURATION

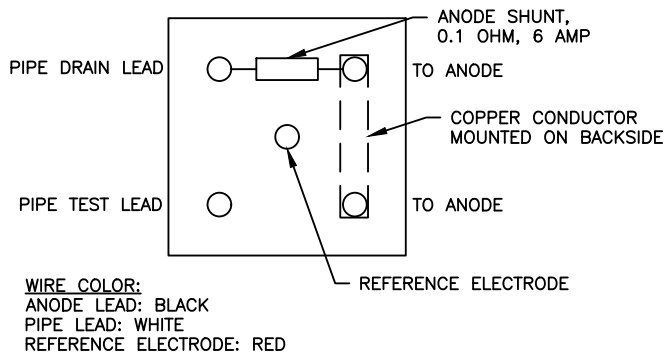

WELD CAP DETAIL

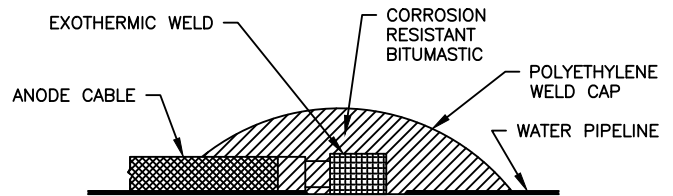

ANODE TEST STATION PROFILE

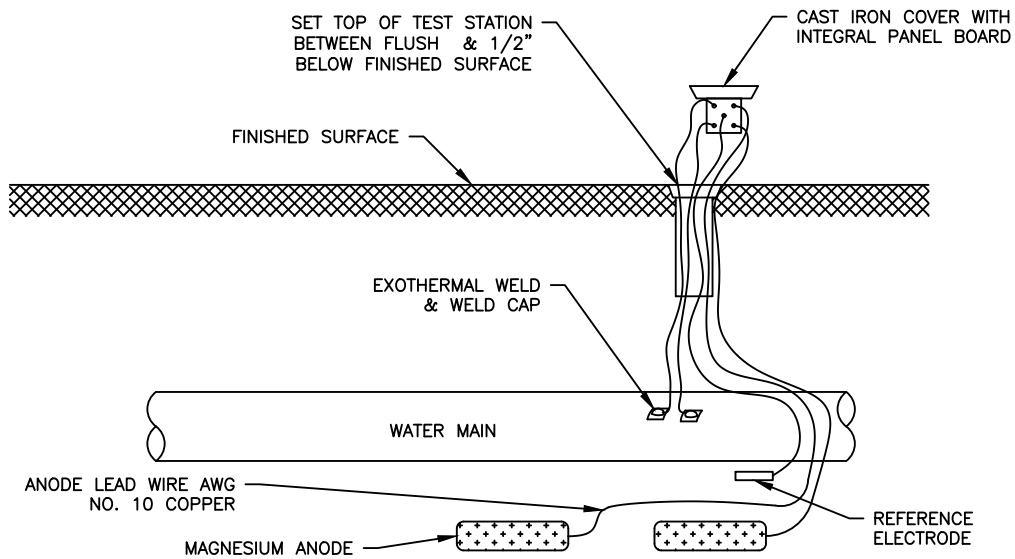

1. REMOVE OUTER PLASTIC WRAP JUST PRIOR TO ANODE INSTALLATION, DO NOT DAMAGE CLOTH BAG PACKAGING.
2. ANODE SHALL BE PLACED 3-5' AWAY FROM PIPE
3. ANODE SHALL BE SOAKED WITH MIN 2 GALLONS OF WATER UPON INSTALLATION TO ACTIVATE

DR. *AMB* DATE. 12/28/2022

CH. *TMJ*

APPROVED

RWH

**SAINT PAUL REGIONAL WATER SERVICES
CITY OF ST. PAUL, MN**

**CATHODIC PROTECTION
ANODE AND TEST STATION INSTALLATION**

STANDARD
PLATE

D-15

1 of 2

SERVICE TAPS ON CI/DI

COPPER SERVICE INSTALLATION/REPLACEMENT

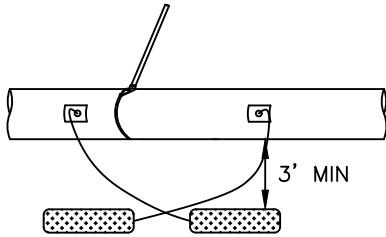

(2) 32 LB (BARE WT.) MAGNESIUM ANODES

LARGE SERVICE INSTALLATION/REPLACEMENT

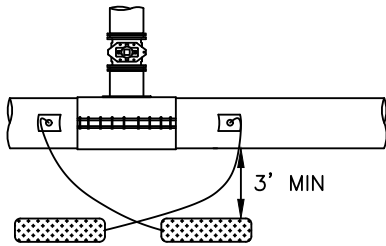

(2) 32 LB (BARE WT.) MAGNESIUM ANODES

GENERAL MAINS REPAIRS

MAIN BREAK REPAIR

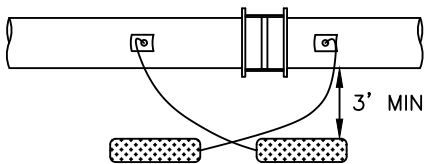

(2) 32 LB (BARE WT.) MAGNESIUM ANODES

VALVE INSTALLATION/REPLACEMENT

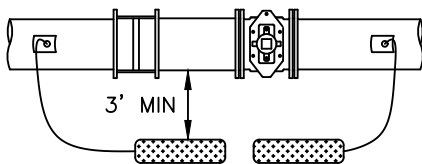

(2) 32 LB (BARE WT.) MAGNESIUM ANODES

CONNECT TO EXISTING MAIN

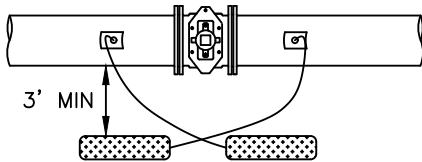

(2) 32 LB (BARE WT.) MAGNESIUM ANODES

SERVICE TAPS ON HDPE/PVCO

COPPER SERVICE TAP TO HDPE

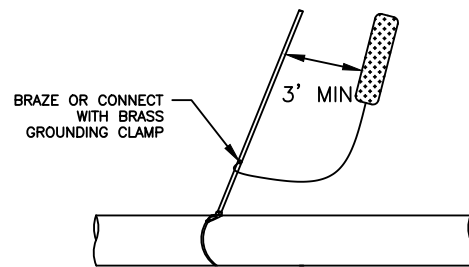

(1) 5 LB (BARE WT.) ZINC ANODE

LARGE SERVICE CONNECTION TO HDPE

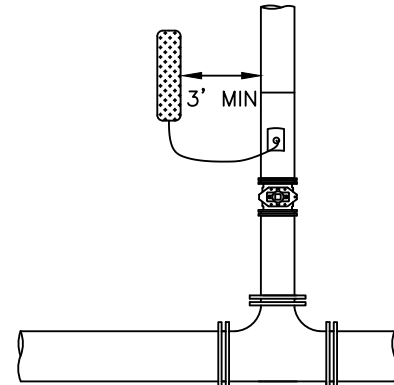

(1) 32 LB (BARE WT.) MAGNESIUM ANODES

HYDRANT WORK

HYDRANT INSTALLATION/REPLACEMENT

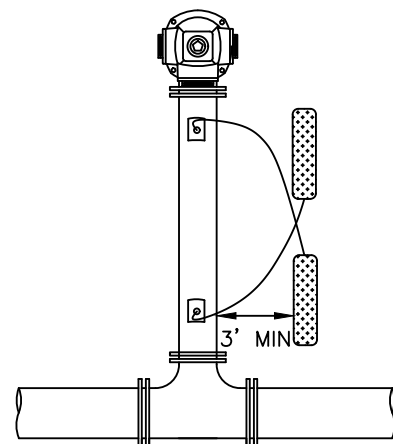

(2) 32 LB (BARE WT.) MAGNESIUM ANODES

DR. *AMB* DATE. 02/03/2023

CH. *TMJ*

APPROVED

RWH

SAINT PAUL REGIONAL WATER SERVICES
CITY OF ST. PAUL, MN

CATHODIC PROTECTION

MAGNESIUM ANODE PLACEMENT (PLAN VIEWS)

STANDARD
PLATE

D-15

2 of 2