

FAIRVIEW

STATION AREA PLAN



Adopted October 22, 2008



URBAN
STRATEGIES
INC.

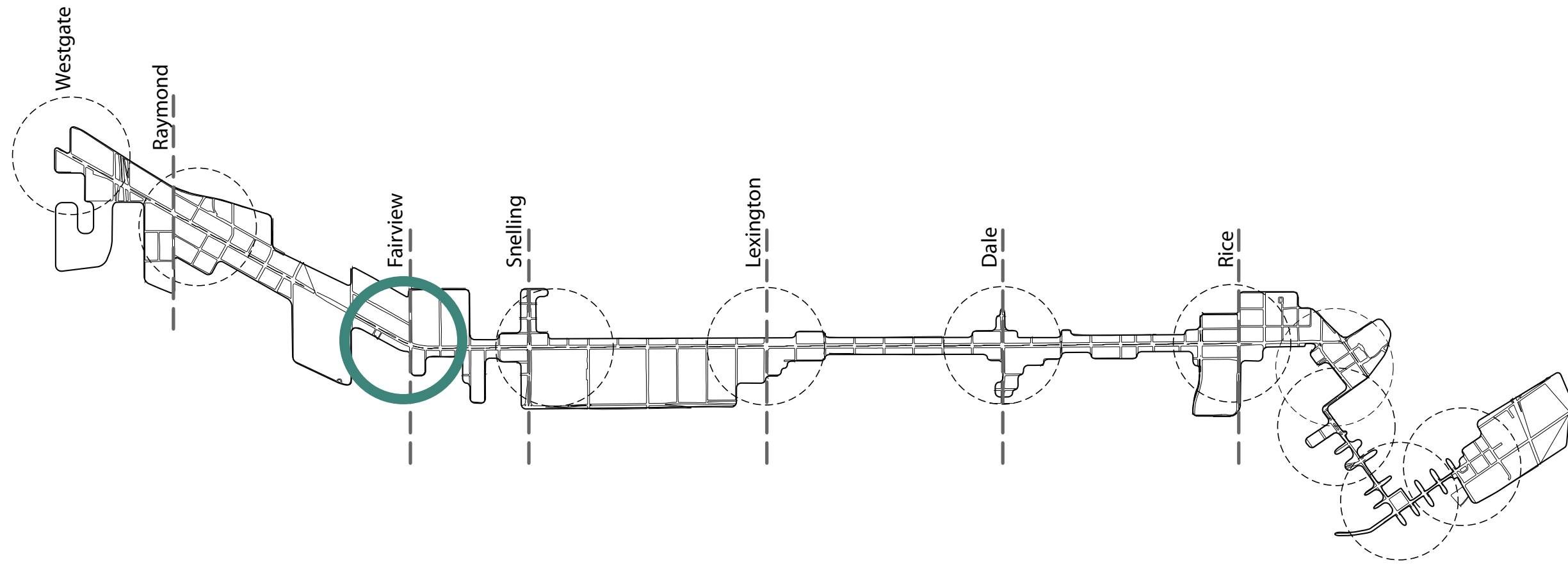

Table of Contents

1	The Fairview Station Area Today	- 05 -
2	The Future of the Fairview Station Area	- 11 -
3	Public Realm - Creating Places	- 17 -
4	Future Character Areas - Built Form & Land Use Policy Directions	- 23 -
5	Movement - Balancing Modes	- 37 -
6	Getting There	- 43 -

The Station Area Plans, Introduction, and Moving Forward chapters are adopted as addenda to the Central Corridor Development Strategy.

Planning for the Central Corridor

As stated in the Central Corridor Development Strategy (CCDS), Light Rail Transit (LRT) along the Central Corridor represents a tremendous opportunity for Saint Paul to become “a place that has stronger businesses, more vibrant neighborhoods, and more beautiful urban places.” The CCDS establishes a set of strategies for how the Corridor should grow and change over the next 25-30 years in response to the LRT investment. The station area plans, using the foundation of the CCDS, provide a more detailed framework for integrating decisions about future land use and development; the public realm; and the movement of LRT, buses, cars, pedestrians, and bicycles at each station area.

Planning for the Central Corridor is an opportunity to focus and guide future investment, both public and private, to create a stronger, more vibrant community that is a better place to live, work and do business. The goal is to support economic development and overall corridor prosperity that result in new housing at all income levels, more and better jobs, and more business activity. The resulting increases in the property tax base and sales tax revenue will provide the resources for additional public services and infrastructure that, in turn, support economic development activity. The plans focus on an improved movement network, high-quality design, and improved open space and pedestrian amenities that will support and encourage economic investment, as well as create a more livable, attractive and vibrant community.

Station Area Plans and Future Development

The station area plans were developed through a series of community-based roundtables, workshops and open houses, guided by a steering committee of community representatives. Property owners, residents, business owners, and institutional and organizational representatives participated in this grass-roots process.

3-D Model of the Corridor. During the workshops, participants created a 3-D model of potential future development at station areas. The model depicts potential new buildings, open spaces and other public realm improvements. Since there is little vacant land along the Corridor, most of the change depicted involves redevelopment and replacement of existing buildings and surface parking lots. While photos of the model are used throughout these plans to illustrate how the principles and objectives for new development could be realized, it is important to note that the model represents only one of many possible development scenarios. The model is not intended to prescribe how new development will look, but to present one example of how the vision, goals, and objectives of these plans might be realized. The intent was to model potential building height maximums, open spaces and streets to demonstrate transit-supportive developments for individual parcels.

Change Over Time. Change will occur when individual property owners decide it is either the right time to reinvest in their properties, sell to someone else who will reinvest in the property, or the City has the resources and appropriate public purpose to purchase property. Change will happen incrementally over time, and likely more slowly until LRT is up and running.



The Fairview Station Area Today

This chapter provides a snapshot of the Fairview Station Area's history and a brief description of the physical conditions that are shaping the role and character of the Fairview Station Area today.



The History of the Fairview Station Area

In the mid-19th century the Fairview Station Area was a wide stretch of prairie between the two small towns of St. Paul and St. Anthony.

Although the first railroad in the state, which opened in 1862, traveled through the area near present day St. Anthony Ave., it did little to attract settlers. However, the establishment of the Minnesota Transfer Railroad, organized in 1883 and still in business, was a major impetus to the industrial and commercial development of the area. Another impetus for commercial and residential settlement was the completion in 1890 of the University Avenue streetcar line, the first line to connect the Minneapolis and Saint Paul track systems. The Iris Park neighborhood, just west of Fairview Avenue, developed as a middle class residential neighborhood around Lake Iris, which was the site of a former amusement park called Union Park.

One of the most significant building complexes at the station area today is the Griggs Midway complex. The sprawling campus of former industrial buildings is located on the north east corner of Fairview and University Avenues. These three and four story concrete structures were built in phases between 1910 and 1920 for Griggs Cooper & Company and the Sanitary Food Manufacturing Company. Griggs Cooper & Company was incorporated in 1900 as the successor to a number of wholesale grocery firms dating back to the early 1880s. Several packing and canning plants were located around the state and processed foods grown locally. The firm developed its own labels including “Home Brand”, “Bengal Brand” and “Sanitary Seal” for its baked goods, and soon expanded into production using foods from around the world including spices, coffee, syrups, cheese, olives, herbs and vegetables. With its extensive shipping requirements, Griggs Cooper began to manufacture its own containers including cans, crates, boxes and baskets.

In the 1960s Griggs Cooper sold the food distribution business and a portion of its production and distribution facilities. The building complex gradually converted to office uses, and today houses many businesses and non-profit organizations. The area has attracted other institutional and non-profit uses, including Goodwill, the Midway YMCA, Episcopal Homes, and numerous public charter schools.



FIGURE 1.1 - University Avenue, 1918



FIGURE 1.2 - Griggs Midway, 1955

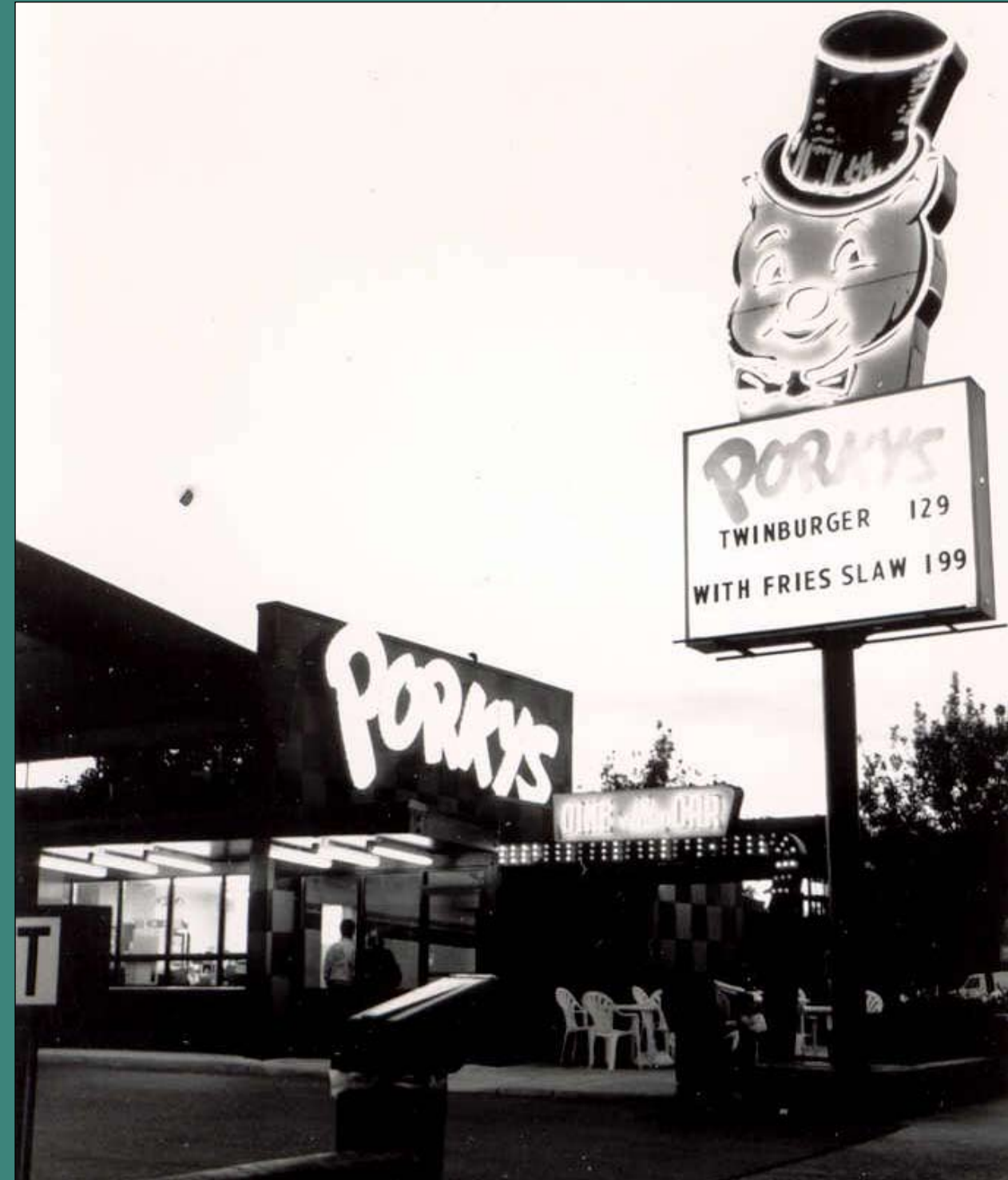

FIGURE 1.3 - Porky's Restaurant, 1991

Source of photos: Minnesota Historical Society

The Fairview Station Area Today

The Fairview Station Area consists of distinct residential and employment districts separated by the Avenue.

The northern half is characterized by a range of small-scale employment and non-governmental uses housed within an eclectic mix of turn-of-the-century and mid-century structures on larger blocks and parcels. To the northeast, the large block structure and industrial character inhibits pedestrian connections between the Avenue and adjacent neighborhoods. To the northwest, the employment cluster becomes more industrial in nature and includes a transformer station and large format home improvement retail store.

In contrast, the southern half of the Station Area includes the Iris Park and Howard Park neighborhoods, which are book-ended on the east by the Health East medical clinic and on the west by industrial uses. Pressures from these adjacent uses have frayed the boundaries of these neighborhoods over the years and created instability along their edges.

These distinct halves are tenuously connected by a linear cluster of commercial and institutional uses oriented towards the Avenue. Uses along University itself are characterized by a high concentration of social service and non-profit agencies. A mix of larger commercial buildings and small-scale retail and commercial storefronts, not all of which are occupied, offer an opportunity for a diverse mix of employment opportunities and destinations close to the LRT.



FIGURE 1.4 - The Fairview Station Area today is characterized by a strong employment and industrial presence north of the Avenue, and a residential presence south of the Avenue. An opportunity exists to tie together the two sides of the Avenue.



FIGURE 1.5 - An example of some of the public art that exists within the Station Area, marking a pedestrian connection north to the **Goodwill** offices.



FIGURE 1.6 - Buildings such as this at 1919 University house a range of **social service and non-profit agencies**.



FIGURE 1.7 - **Dickerman Park**, though not fully realized, is an important park space north of the Avenue with tremendous opportunity to transform the character of the Station Area.



FIGURE 1.8 - Buildings currently lack a coherent relationship with **the Avenue**.



FIGURE 1.9 - The **Episcopal Homes** development helps to improve the relationship between the residential neighborhood of Iris Park and the Avenue.



FIGURE 1.10 - **Iris Park** sits at the heart of the Iris Park neighborhood and creates a place of respite along the Avenue.



The Future of the Fairview Station Area

2

The Future of the Fairview Station Area chapter describes:

- **the planned location of the future LRT platform;**
- **forecasted market opportunities for new growth and investment;**
- **a description of the Station Area Boundary and Areas of Stability and Change within the Fairview Station Area; and**
- **a vision statement describing the future potential role and character of the Station Area with regard to both the immediate community and the broader Central Corridor .**

The Future of the Fairview Station Area

The Fairview Station Area has strong potential to distinguish itself as a vibrant place along the Avenue.

Even in advance of investment in LRT, the area's recent and planned developments including Episcopal Homes, the Griggs Midway and Goodwill Buildings, strong neighborhoods, and role as a services and programs hub, speak to the potential of this Station Area. The Fairview Station Area will be a complete and healthy community with vibrant public spaces, a range of movement options, a diverse mix of uses, and attractive buildings framing lively, pedestrian-friendly streets.

2.1 Fairview Platform

The future Fairview LRT platform is currently planned as a center split platform in the vicinity of Iris Park.

Traffic operations at the intersection of Fairview and University will continue to operate largely as they do today, with traffic lights controlling all vehicular, pedestrian and LRT movement through the intersection.

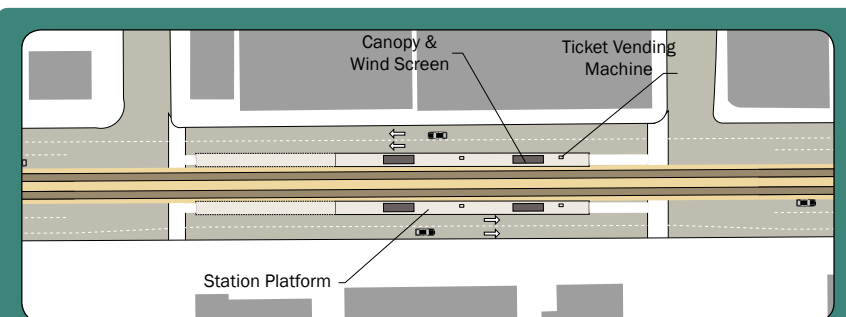

FIGURE 2.1 - Typical Center Split Platform

2.2 Market Forecast

It is estimated that within the next 25 years, the Fairview Station Area will grow modestly in both housing and commercial development, while continuing to diversify its employment, residential, institutional and destination retail base (Figure 2.2).

The table below provides the estimated breakdown of the total potential development within the Fairview Station Area over the next 25 years.

Fairview Station Area Market Potential						
	Market Forecast 2030 January 2008	Pre-Construction 2008-2009	During Construction 2010-2014	Early Operation 2015-2020	Mature Operation 2020-2030	Specific Market Opportunities
Residential: Rent	400-500	0	0	150-200	250 - 300	Potential for additional senior housing (campus?)
Residential: Own	200-300	0	0	50-100	150 - 200	Senior Housing Potential
Office Space (sq ft)	300,000	0	50,000	100,000	150,000	Campus synergy for social services may drive office/institutional development
Retail Space (sq ft)	40,000	0	0	15,000	25,000	Ground Floor of Mixed use, CDC, UniFairview
Industrial sq ft	Consolidate	-	-	-	-	-
Hotel Rooms	-	-	-	-	-	-

FIGURE 2.2 - The Fairview Station Area Development Forecast predicts modest growth with opportunities for mixed use infill development and additional community facilities.

2.3 Defining the Study Area

The Fairview Station Area has the potential to evolve as a place with strong businesses, more vibrant neighborhoods and new and enhanced public spaces. The Station Area Plan process used four mapping layers to investigate and understand the Raymond Station Area.

The Station Area Plan process used four mapping layers to investigate and understand the Fairview Station Area. The Station Area Boundary extends beyond the conventional one-quarter mile station area boundary to capture the disparate north/south residential and employment characteristics here and to consider the range of potential the LRT offers for enhancing these areas. Within the boundary, a refined Area of Change has been delineated through the station area planning process. The Area of Change denotes where change is welcome and should be encouraged within the Fairview Station Area, whether through gradual infill and/or intensification or comprehensive redevelopment.

Finally, the current and future area of high pedestrian activity has been identified as a Mobility Enhancement Area. Section 5.0 of this Plan presents recommendations for balancing modes of movement within this active hub.

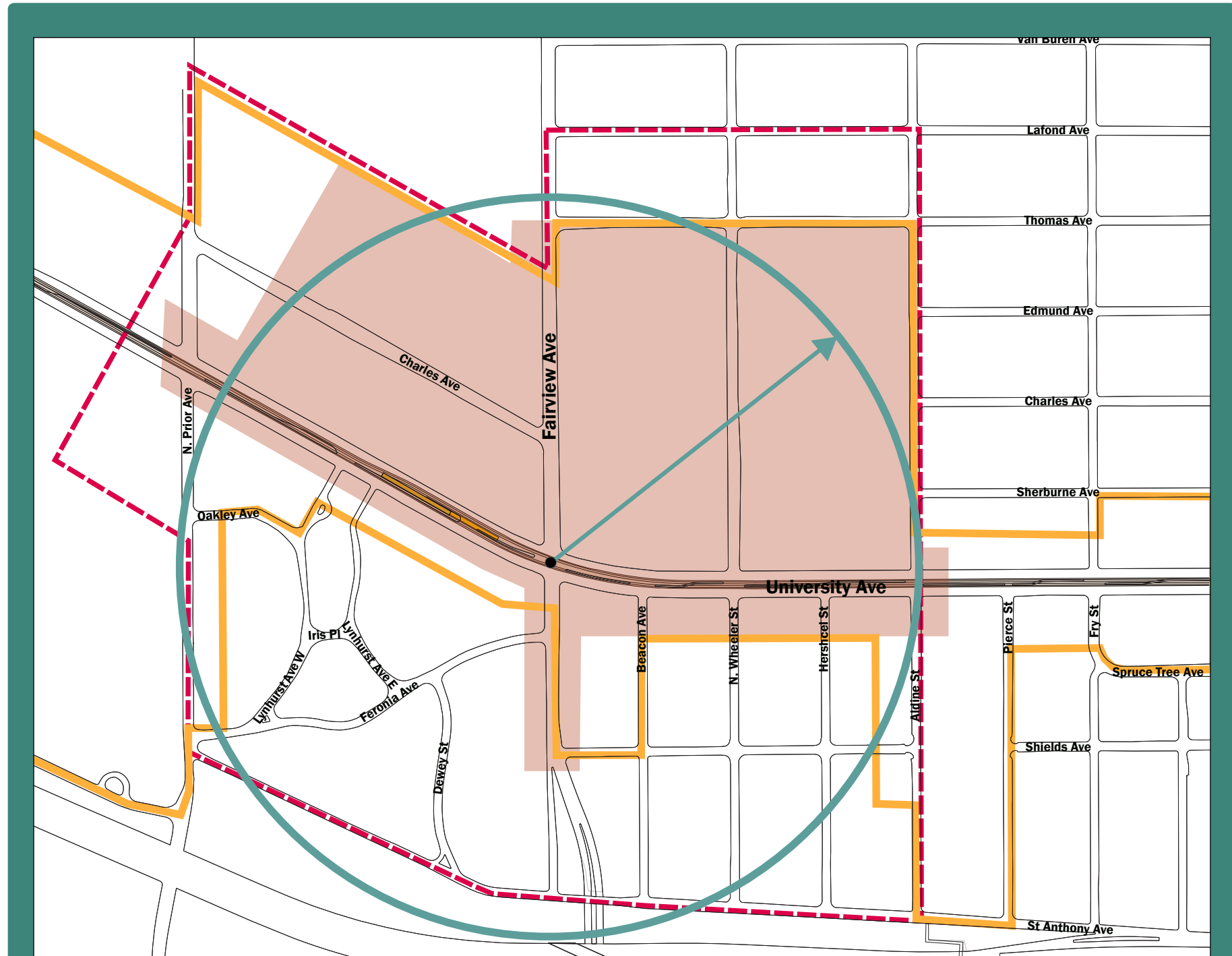

FIGURE 2.3 - The Four Lenses of Exploration illustrate the evolution in understanding the Fairview Station Area.

- Mobility Enhancement Area
- Revised Area of Change and Stability (Revised Fall 2007)
- 5-minute Walking Radius (1/4 mile)
- Station Area Planning Boundary

The Future of the Fairview Station Area

2.4 Looking Ahead - The Fairview Station Area in 2030

Looking Ahead describes a community-crafted vision for the future of the Fairview Station Area. This narrative generally describes the sum of desired characteristics for this community, and its future role within the broader Central Corridor.

Future public and private investment within the Fairview Station Area must focus on repairing and strengthening the relationships between Fairview's many uses and communities, in particular through reinforcing University Avenue as the common seam.

There are three critical components required to stitch these various communities back together:

- shared open spaces where area residents, employees and visitors will interact
- a strengthened University Avenue with a strong civic focus and expanded retail offering for local residents and workers
- an expanded and recaptured system of linear civic and green gathering spaces that frame the Avenue.

As employment uses in the area expand over time, the current social services hub will evolve as an urban campus, linked across Fairview Avenue and with increased opportunity for north/south connections to the Avenue. This district should express a distinct identity, that builds on the string of public spaces along University; reinforce existing and create new legible connections with the surrounding community; and fill in major gaps between buildings to strengthen the urban feel of the place.

Fairview Station Area Vision:

A healthy and functioning “Main Street” with buildings, open spaces and many connections oriented towards University Avenue; and whose activities, uses and destinations are expressive and supportive of the diverse and daily needs of the surrounding residential and business community.

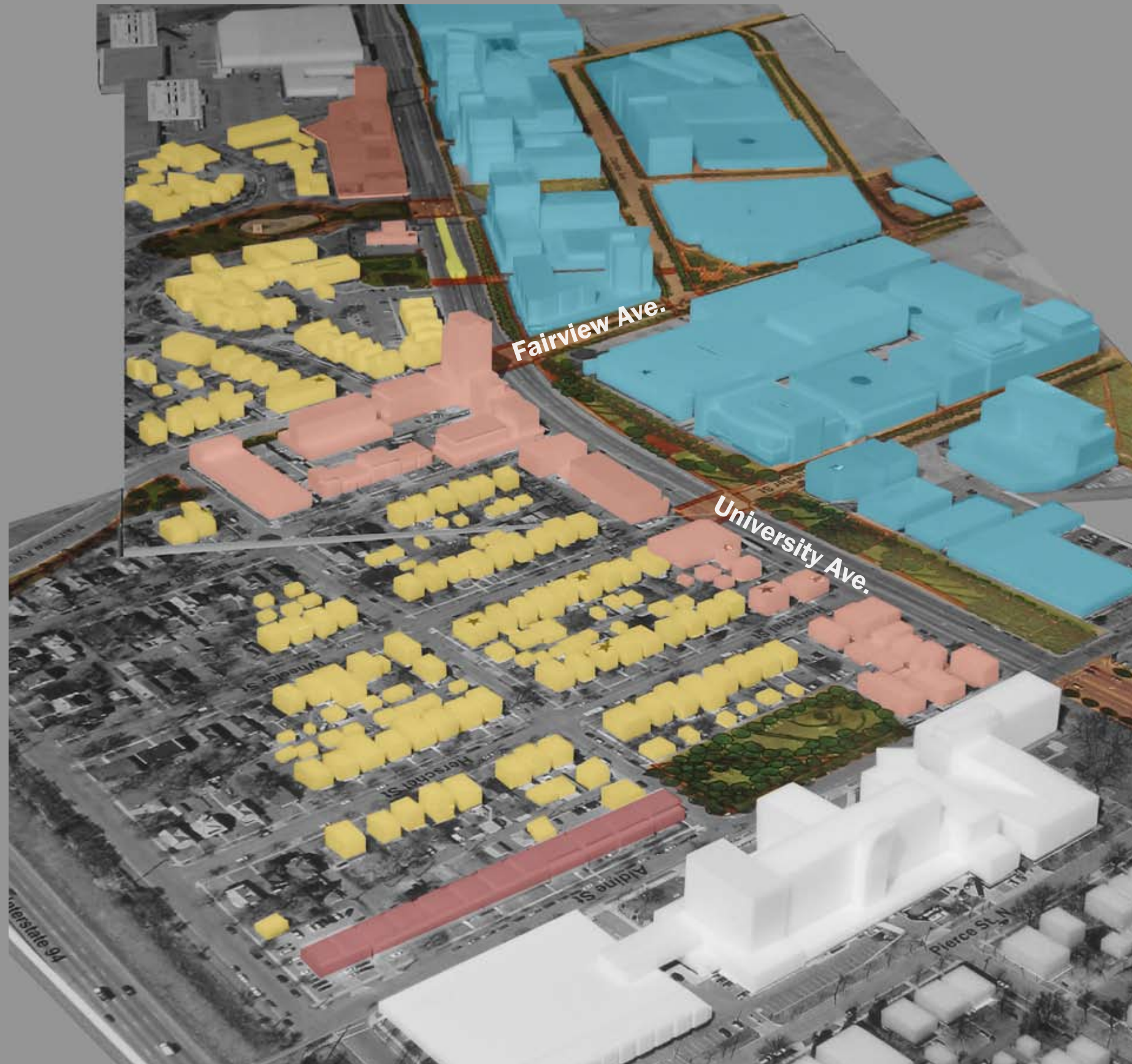

FIGURE 2.4 - The Fairview Station Area 2030 - The physical model shown above illustrates one possible long-term scenario for meeting community, place making and transit-supportive opportunities. Rather than attempting to predict the location and distribution of anticipated long-term investment, this conceptual model illustrates the application of transit-supportive principles throughout the entire Station Area. The total development yield illustrated is therefore not meant to be precisely representative of the 2030 market forecast (Figure 2.2) for this Station Area, but demonstrates examples of transit-supportive developments for individual parcels.



Public Realm - Creating Places

The following *Key Moves* identify priority investments for improving the public spaces and pedestrian environment in the Fairview Station Area in a manner consistent with the Vision of the Central Corridor Development Strategy: a beautiful urban place with pedestrian-friendly, attractive tree-lined boulevards. These recommendations explore opportunities for streetscaping, new passive and active park spaces, community gathering places and expressions of public art.

Public Realm - Creating Places

Fairview is one station area along the Avenue where existing and planned public spaces can be found directly along the University Avenue frontage.

Iris Park demonstrates the potential for public spaces to offer a “front door” to the street but also provide important green relief along the Avenue. Dickerman Park holds tremendous potential - if realized as a public park space - to revitalize and distinguish this segment of the Avenue. These two spaces symbolize the potential for public spaces to play a defining role for Fairview Station. They also highlight the role green space could offer in reinforcing the Avenue as the gathering point between a working and living environment - both of which are key in transit-supportive communities.



FIGURE 3.1 - The **Public Realm Plan** identified here illustrates one possible configuration of an improved network of open spaces and pedestrian routes.

A Public Art Opportunities

3.1 Fairview's Public Realm: Key Moves

Iris and Dickerman Parks offer the first clues to an expanded armature of green spaces that may create Saint Paul's 'park station' on the LRT corridor. The following six *Key Moves* will guide future investment in the public realm.

A minimum of 14-foot sidewalks should be established within the "Mobility Enhancement Area" defined for each station area. The Mobility Enhancement Area is the area around each station where a higher level of pedestrian activity is anticipated and a high-quality pedestrian environment is key.

This proposed new green space (Figure 3.2) at the corner of Edmund Avenue and Wheeler Street might emerge as a result of a land transfer involving the additional 30 foot strip of land in the Aldine Street right-of-way. It should serve as the focal point for an expanded employment campus, including expansion of the Griggs Midway Building, an expanded Midway YMCA and other new commercial buildings north of University Avenue and east of Fairview Avenue.

New Griggs Midway Commons



FIGURE 3.2 - The **Griggs Midway Common** is the central gathering space for the larger employment campus.

This outdoor gathering space should link the preferred east-west bicycle routes located along Edmund Avenue (west to Prior Avenue) and Charles Avenue (east all the way to Rice Street). This space should be designed to function as a green, passive gathering space for area workers to gather and relax outdoors. In addition, an existing generous road right-of-way along Wheeler Street offers the opportunity to extend a greenway connection from the Avenue to the new Griggs Midway Commons.

Dickerman Park



FIGURE 3.3 - A reclaimed **Dickerman Park** could set the standard for public space along the Avenue.

Reclaiming and restoring Dickerman Park back to its originally- intended use as a linear urban park space will help establish an identity for the area, provide a green buffer from the Avenue, establish a valuable frontage for building reinvestment, set a standard for establishing additional green ribbons along the Avenue and provide a visible locale for public art that expresses the identity of the neighborhood. It is also a key opportunity to provide a visible locale for public art that express the identity of the neighborhood.

Avenue of Parks



FIGURE 3.4 - The extension of Dickerman Park westward will create a remarkable **Avenue of Parks** and distinguish the Fairview Station Area along the corridor.

Extending the linear pattern set by Dickerman Park west of Fairview to the LRT station would create a remarkable green spine that distinguishes Fairview and enhances physical and visual connections along the Avenue. This setback is envisioned as setting the precedent of a green and generously landscaped mixed-use corridor punctuated with open spaces that draw people into the area's neighborhoods and employment centers. There is further potential to augment this linear pattern by providing connections with remnant private open spaces, such as the forecourt of Health East and the Episcopal Homes storm water ponds. As a composite, these spaces would contribute tremendously to the role of University as a seam to bring together residential and employment communities.

Charles Commons - Creating a "Park Station"



FIGURE 3.5 - The extension of Iris Park north to create a **Charles Commons** will embed the station in a park-like setting and connect the LRT to the employment campus to the north.

The proximity of Iris Park to both University Avenue and the future Fairview LRT platform creates an excellent opportunity to improve the connection between the station and the neighborhood, and to incorporate an existing open space into the experience of using the LRT. The landscaped forecourt of Iris Park Place directly opposite the park creates an additional opportunity to extend the amenity of this important asset across the Avenue. Extending this green swath further to Charles Street will position the historic Iris Park Place structure in a park-like setting and create a proposed Charles Commons off of the Avenue. This new Commons will help to structure development along Charles Street and act as a focus for the employment campus west of Fairview Avenue.

Health East Healing Gardens



FIGURE 3.6 - There is opportunity to reclaim the surface parking adjacent to The HealthEast Midway Clinic and repair it to create **healing gardens**.

A future community garden, designed as a naturalized and restorative space, should replace the northern portion of the surface parking area in order to repair and restore this street and create a new amenity for clinic patients, staff, and the surrounding community.

Public Art Opportunities



Figure 3.7 Dickerman Park, a linear green space on the north side of University between Fairview and Aldine is envisioned as an interactive landscape with permanent and temporary art installations.

Digital renderings courtesy of Coen + Partners

Public art should be integral to all future development and public realm projects within the Station Area. The public art collection should express distinct station area character as well as the wholeness and continuity of the corridor.

Public art is:

- 1) The result of including artists on professional design teams to affect space design from the initial stages of planning;
- 2) The creation of site-specific objects to beautify public spaces, improve their function and enhance their meaning in the community; and
- 3) The creation of site-specific experience using various art forms and media, including time-based works, to enhance the sense of place.

Public art strategies should engage both public agencies and private property owners and developers as they build the city.

While public art opportunities are broadly available to national and even international artists, special efforts should be made to engage local artists. Artists engaged in shaping the form and experience of the key station areas should consider the following concepts and opportunities identified through the workshop process:

- The concept of University as an **“Avenue of Parks”** offers opportunity to explore and interpret the history and evolution of the Avenue and of University as a whole;

- **The Health East Healing Gardens** offer opportunity to express healthy community and celebrate the Howard Park neighborhood;
- **Griggs Midway Commons and Charles Commons** offer opportunity to explore the character of these passive gathering places and enhance their function at the core of a high-density employment campus;
- **Dickerman Park**, co-designed by a landscape architect and artist, is a model of artist engagement in collaborative design of public place. Its approved design offers opportunities for interactive public artworks and installations;
- **Goodwill Forecourt** area offers an opportunity to enliven the experience of approach to the LRT station and the routes between the station and the larger neighborhood; and
- **Fairview Parks LRT Station** offers opportunity to define and distinguish the station and its surrounding community, to tell the story of the area’s rich and evolving cultural history, and to express the significance of LRT as a public asset for the residents, students, workers and visitors it serves.



Future Character Areas - Policy Directions

Recognizing the diverse places within each station area, a series of distinct *Character Areas* has been identified for the Fairview Station Area.

Utilizing a series of working 3D foam models produced in community workshops, this section builds on the transit-supportive development types identified in the Central Corridor Development Strategy to describe historic and emerging *Character Areas* within the Fairview Station Area. Each *Character Area* contains a series of policy directions to guide future investment and change in built form, land use and circulation over time. These directions include identifying the appropriate location and scale of taller buildings; strategies for transitioning to stable neighborhoods; a desirable mix of transit-supportive uses; and recommendations for accommodating a system of movement that balances modes of active, transit and automobile transportation.

This section is illustrative of how the goals and objectives of the station area plan may be realized. It is intended, in the case of transit-supportive development or other development that will increase density within station areas, that the policy directions under this section be interpreted to support flexibility in the application of these guidelines in order to achieve transit-supportive or denser development within station areas.

Future investment in Fairview's Station Area should build on five distinct *Character Areas*.

Future development in the Fairview Station Area should preserve the integrity and character of the existing residential and viable employment uses, while continuing to promote new and diverse transit-supportive development. A flexible land use strategy should be employed to emphasize connectivity, design performance, transit-supportive qualities, a mix of uses, active first floor frontages, and shared parking solutions. Together, these approaches will strengthen University Avenue's role as a community seam and reinforce the fabric of the area as a complete community with housing, employment and options for all.

While this overall direction will help guide change over the entire Fairview Station Area, this section describes five areas (Figure 4.1) that will require specific policy direction to achieve their built form and land use potential over time. The following *Character Area* descriptions and policy directions respond to these distinct areas and provide clear guidance to the forms of development that will support the potential of the broader Station Area.

Each *Character Area* relies on images of a demonstration model to illustrate key structuring principles for the area, including a narrative describing the general character and structure of the place; and a series of policies that provide guidance relative to the distribution of building heights, massing, block structure, transition to lower intensity neighborhoods, and circulation.

The final section of the chapter outlines common policy directions for parking and access that apply to all of the *Character Areas*.

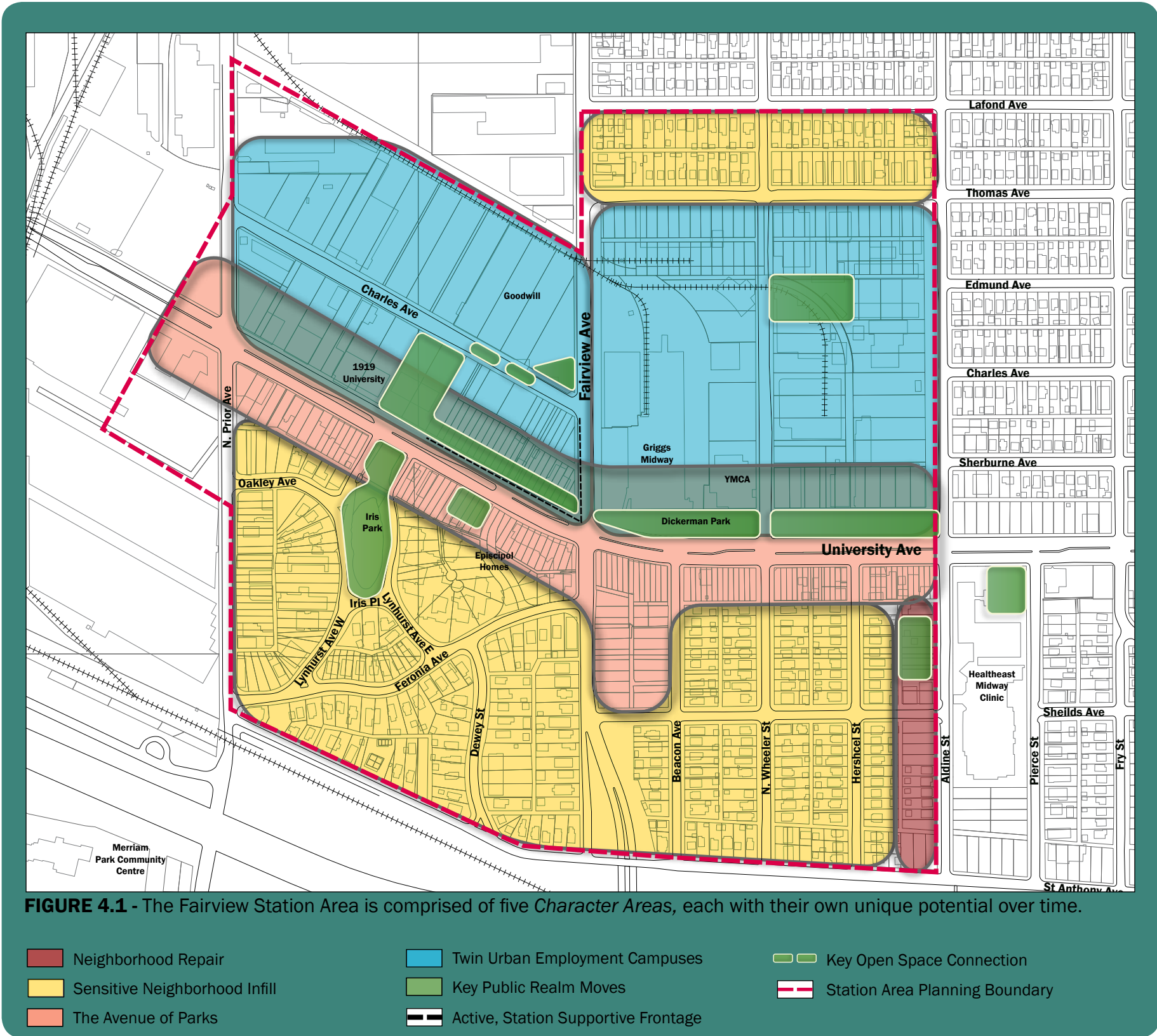

4.1 Twin Urban Employment Campuses

Building on the existing concentration of employment and social service uses within the Fairview Station Area, future redevelopment should bring together these land uses into a cohesive campus environment.

The campuses should utilize University Avenue as their primary frontage and principal address. Fairview Avenue should act as an important north-south route that will provide balanced modes of access to each campus and act as a delineator between them.

Each campus should be oriented around a series of open spaces, including a revitalized Dickerman Park along University Avenue for the east campus and two new passive green space (the proposed Charles and Griggs Midway Commons for the west campus). These will provide both meeting and resting places for area workers, create secondary addresses away from the Avenue and help to foster synergies between the many related businesses in the area.

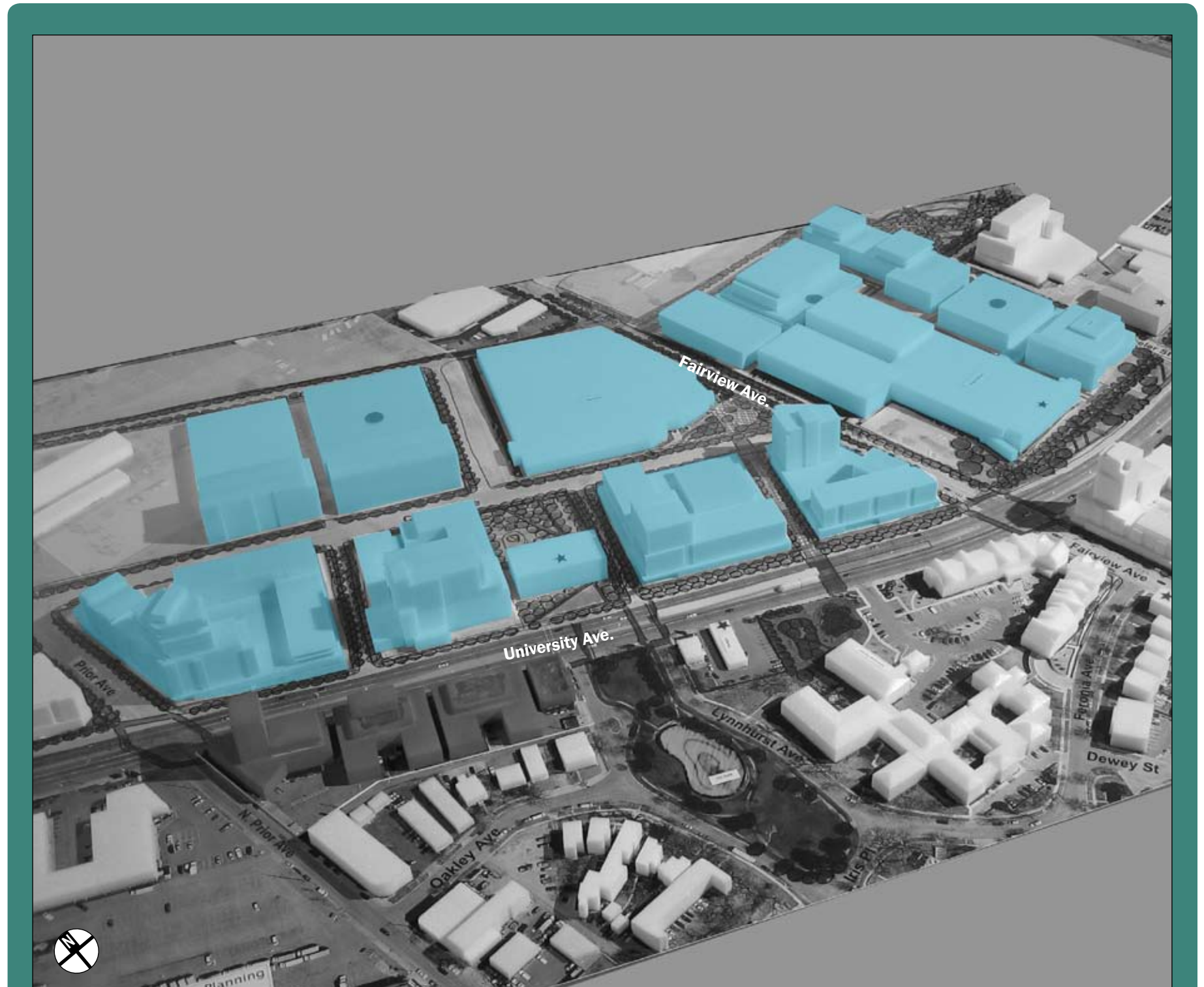

FIGURE 4.2 - The model illustrates the potential for the creation of **Twin Urban Employment Campuses** oriented around two new open spaces. The model is intended to represent one possible built form scenario, and it is not intended to be interpreted as prescriptive for evaluating future development proposals.

4.1.1 Built Form

Create twin urban employment campuses.

- The design of buildings along University Avenue should respect the historic character of the Avenue and exhibit an architectural quality that defines the edge and primary interface of this employment campus.
- Large floor plate commercial developments should be permitted.
- Building heights should generally be in the range of 3-4 stories fronting the Avenue. Possibilities for greater height in the range of 8-15 stories exist on larger redevelopment parcels fronting onto University west of Fairview. In these instances, a base building in the form of a 3-4 story podium should be provided to help diminish the visual presence of the taller buildings from sidewalk level.
- New buildings not facing onto University should generally be a minimum of 4 stories. Where facing public open space, 6-8 story buildings may be permitted.
- All development should contribute to a coordinated landscaping and streetscaping program for University Avenue, Fairview Avenue and Charles Avenue.
- Where there is not sufficient public right-of-way for the proposed linear public space system, new street tree plantings or public realm amenities, new buildings should be setback from property lines to establish an outdoor area for seating, display space and/or landscaping as appropriate. Parkland dedication provisions for any future development on the north side of University west of Fairview should encourage the dedication of land.

4.1.2 Land Use & Development Pattern

Promote an employment and social services hub.

- Land use should be geared primarily to higher-intensity employment uses, such as offices, business incubators, educational facilities, social services provision, and light manufacturing and production.

- Along University Avenue, a full range of commercial and residential uses and integration of uses within buildings is encouraged. Block faces identified as Priority Active Frontage should be activated with retail, café and live/work uses.
- A limited amount of neighborhood retail (cafes, corner stores and other service uses) should be permitted adjacent to Fairview and Charles Avenues. These ancillary uses and services should be restricted to the first floor of new buildings, with all entrances oriented towards their principal facing streets.
- Large format retail is prohibited within this Station Area. Retail should only be permitted as a secondary use within a mixed use development and should not exceed more than 20% total Gross Floor Area of buildings.

Accommodate servicing.

- Charles Avenue should be maintained as a public street that balances all modes of movement. Where conflicts with servicing and loading functions constrain or conflict with other activities on Charles Avenue, alternative locations should be explored for accommodating these important activities.

4.1.3 Circulation, Parking and Access

The urban grid pattern should be re-introduced.

- Where large single parcels of land exist, they should be subdivided to create a more walkable environment of smaller scaled streets and blocks. The proposed extensions of the urban grid pattern listed below are illustrated in Figure 5.1
 - Where possible, the existing streets east of Aldine Street should be extended across to Fairview Avenue.
 - The extension of Edmund Street west to Prior Avenue will help to ease congestion on Charles Street by providing a service route for existing businesses.



FIGURE 4.3 - Focusing office and employment uses around a plaza or open space system such as in these employment areas in London, UK, can not only help to create an address but can encourage employee interaction and synergies.

4.2 An Avenue of Parks

This stretch of the Avenue, lined with placemaking park spaces, functions as both a gateway to the employment campuses and a “Main Street” serving adjacent housing.

This stretch of the Avenue, lined with park spaces, functions as both a gateway to the employment campuses and a Main Street serving adjacent housing.

In this role it will function as a seam between two very distinct yet inter-connected areas. Along the northern side it will identify the threshold of the two employment campuses while along the southern side it will provide both a transition and interface between the Avenue and the adjacent residential neighborhoods.

Over time, the Avenue must evolve as a mixed-use corridor with a high concentration of low to medium-order goods and services that cater to the area’s employment and residential markets. The enhancement of existing parks and introduction of new public spaces as a key structuring and distinguishing feature – an Avenue of Parks - will be key to the future of the Fairview Station Area.



FIGURE 4.4 - The model illustrates the potential for the creation of an **Avenue of Parks** along the corridor.

4.2.1 Built Form

Reinforce a mixed-use corridor streetscape.

- Along the south side of the Avenue, new development or expansion of existing buildings should be predominantly low to mid-rise in scale, up to 2-3 commercial stories in height.
- In several locations, taller 'point towers' (Figure 4.5 bottom) of 8-10 stories may be appropriate especially at key intersections and adjacent to park spaces including the northwest and southeast corners of University and Fairview, adjacent to the proposed Charles Common; and at the intersection of Prior and University. These should be setback from the base podium height in order to reduce their impact at street level.
- Along the north side of the Avenue, new development or expansion of existing buildings should be predominantly low to mid-rise in scale, up to 3-4 commercial stories in height. West of Fairview, taller buildings up to 6 commercial stories in height stepped back above the 3rd floor are appropriate.

All new development should promote transparency and activity at street level.

- Ensure first floor units and storefronts have at least one entrance open to the Avenue, access points to the station platforms, and/or key gathering places.
- Commercial or retail uses located at the first floor should help to animate the street by incorporating large glass frontages that allow the activity within to be seen from the street.

4.2.2 Land Use & Development Pattern

Urban infill along the Avenue should have many uses.

- A broad mix of uses should be concentrated along the Avenue where they afford easy access to public transit, and benefit from the visibility and profile of being located on a major transportation corridor, adjacent to an existing community and incubator business hub.

Minimize the impact of surface parking.

- Major redevelopment sites, in particular the Griggs Midway and Goodwill site, should be explored for shared, structured or below grade parking.

All new private development must contribute to adjacent streetscape improvements.

- Where there is not sufficient public right-of-way for new street tree planting or public realm amenities, new buildings should be setback from property lines to establish an outdoor area for seating, display space and/or landscaping as appropriate. A minimum pedestrian promenade dimension of 14 ft. would provide for street trees, sidewalk and some outdoor seating space.
- Developments within the area defined as Priority Active Frontage should provide for active uses at grade to support their immediate proximity to the future LRT station platform.
- Building gaps along the street frontage within the Station Transfer Zone should be discouraged. Where gaps do exist they should be adequately landscaped along the street frontage.

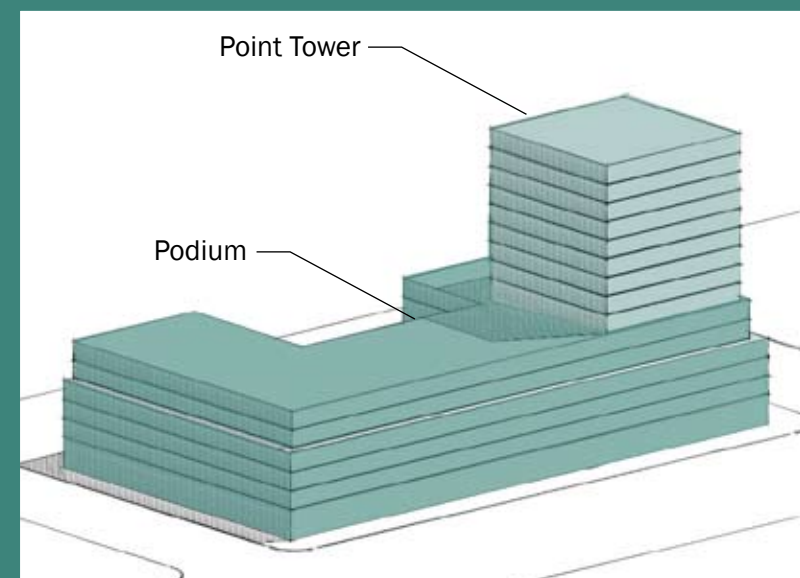

FIGURE 4.5 - Enhanced open spaces along this street in Montreal (top) act as key structuring elements and help to transform the character of a busy street.

An example of a typical 'point tower' (bottom) illustrates how the tower is set back from the base podium to reduce the towers impact at ground level.

4.3 Neighborhood Repair

The recent demolition of single family homes on the west side of Aldine Street for surface parking has negatively impacted the quality and character of the surrounding Howard Park neighborhood.

Continuing this practice will over time destabilize the community by forcing property values down and creating sterile, unmonitored spaces. Immediate efforts are needed to restore this neighborhood edge with new low rise residential buildings and the introduction of a new park space. Critical to undertaking this direction is the construction of structured parking on the Health East site to accommodate the clinic's parking needs.



FIGURE 4.6 - The model illustrates the potential for new complimentary scaled development to **repair the neighborhood** edge.

4.3.1 Built Form and Land Use

- a) To repair the residential character of the existing low-rise neighborhoods, buildings should be no greater than 3 residential stories in height and adopt similar setback and massing characteristics as the existing residential development along Aldine street.
- b) Residential, live/work and parks should be permitted uses.
- c) The surface parking lot west of Aldine Street and north of Shields Avenue should be replaced with a passive green space. Parking should be relocated into structured parking east of Aldine Street.

Minimize the impact of surface parking.

- d) Institutional and commercial parking uses in stable residential neighborhoods should be prohibited. Demolition controls should be instituted to prevent further removal of residential structures for institutional or commercial parking.



FIGURE 4.7 - Filling in the surface parking with similarly scaled housing such as these examples from Saint Paul will help restore and reinforce the neighborhood edge.

4.4 Sensitive Neighborhood Infill

The strong neighborhoods that surround the Fairview LRT Station should be reinforced through reinvestment and sensitive residential infill.

New buildings should respect and fit in with the development pattern, scale and height of adjacent properties. This will entail rehabilitation of existing single-family homes, the construction of new single family and multiple-family townhome dwellings, and the construction of new accessory units.



FIGURE 4.8 - The model illustrates the potential for new infill construction to reinforce the existing neighborhoods within the Station Area.

4.4.1 Built Form

Design for sensitive infill.

- a) All development should be designed with consideration to preserve light, views, and privacy in single-family neighborhoods;
- b) To repair the residential character of the existing low-rise neighborhoods, buildings should be no greater than 3 residential stories in height, and adopt similar setback and massing characteristics to the existing residential development along their street.

4.4.2 Land Use & Development Pattern

Encourage accessory units in areas of stability.

- a) Accessory units and multi-unit dwellings can increase density and housing options in the Fairview Station Area. These additions represent excellent opportunities to repair and strengthen residential properties.

Meet parking needs with existing resources.

- b) All residential parking demand should be met on-street, or where feasible, in private driveways accessed from shared rear alleys.



FIGURE 4.9 - New infill housing such as these local examples will help to fill in the gaps and reinforce the existing neighborhoods.

4.5 Managed Parking Strategies

Accommodating parking associated with existing businesses and residents and new development will be an important challenge as the Fairview Station Area evolves.

To properly assess and manage Park & Ride and Hide & Ride, comprehensive strategies must be implemented so that remaining on- and off-street parking can best serve residents and businesses in the Corridor, and support walkable, transit-oriented neighborhoods.

Clearly, the reliance on surface parking at current development standards is a large contributor to the underutilization of land within the station area. A transformation from surface parking to structured and underground parking will need to happen over time and in conjunction with new development. The following policies provide the direction to facilitate this transformation, critical to the creation of active and vibrant streets within the Fairview Station Area.

- a) The establishment of new single-use surface parking lots on University Avenue, and the expansion of existing lots within the station areas, should be discouraged.
- b) Major redevelopment sites should be explored for opportunities to create shared, structured or below-grade parking.
- c) Where surface parking occurs along University Avenue, it should occur to the side or behind buildings, be limited to a maximum of 60 feet in width (for the provision of two parking aisles and one drive aisle), and utilize landscape buffers to minimize the impact on the pedestrian environment.
- d) Parking requirements should be reduced or eliminated to reduce development costs, support transit ridership and open new possibilities for flexible live-work spaces on smaller sites where on-site parking is not available.
- e) On-street parking opportunities should be maximized to reduce the demand for private, off-street parking. This can be accomplished by minimizing curb cuts on all major streets by consolidating driveways, implementing flexible stall spacing, and utilizing meters and time-limited signage on side streets to ensure higher vehicle turnover.
- f) Access to surface parking lots from side streets or alleys should be encouraged. Curb cuts on University Avenue should be minimized and encouraged as opportunities arise, encouraging shared access with neighboring uses.
- g) The implementation and management of the current residential permit parking system should be evaluated.
- h) Both long- and short-term covered bicycle parking should be provided.



FIGURE 4.10 - A 56-foot wide surface parking lot in Portland, Oregon incorporates features such as permeable paving, integrated bike parking and pedestrian-scaled lighting. It is heavily landscaped and concealed from the street by an integrated former building facade.



Movement - Balancing Modes

This chapter contains strategies for improving options to move to, from and within the Fairview Station Area. These include *Connections* to improve the connectivity, safety, efficiency and quality of pedestrian and cyclist routes; and *The Mobility Enhancement Area*, to provide safe and efficient pedestrian access to the Fairview LRT platform and destinations along University Avenue.

The Fairview Station Area already has a high concentration of uses, some of which with high transit dependency, clustered around the future LRT platform location.

Key activity drivers here include the Griggs- Midway Building (a large mixed-use multi-tenant building housing non-profits and upwards of 1000 employees), the Midway YMCA, Goodwill Headquarters Offices and Distribution Center, Episcopal Homes, and the Health East Clinic.

Recommendations for improving and expanding mobility options are structured here into two key themes:

The first theme is *Connections*, which describes a strengthened pattern of mobility options for pedestrians, transit riders and cyclists in reaching destinations within the Fairview Station Area from throughout the Central Corridor's many neighborhoods and the broader region.

The second theme is *The Mobility Enhancement Area*, which more closely examines the future impact of the LRT on movement patterns in and around the proposed platform location, and provides recommendations for ensuring a safe, efficient and amenable pedestrian experience for area residents, workers and visitors alike.

5.1 Connections

The goal of this section is to identify improved mobility options for pedestrians, transit riders and cyclists in reaching the Fairview Station Area from adjacent neighborhoods and throughout the broader Central Corridor region. A Mobility – Connections diagram (Figure 5.1) identifies key routes to and within the Fairview Station Area, and illustrates recommendations for improving the connectivity, safety, efficiency and quality of these routes for pedestrians and cyclists.

Fairview Avenue Spine

This critical, multi-modal route should be better balanced to accommodate and encourage pedestrian activity. Key to this balance will be the calming and re-design of Fairview Avenue through marked pedestrian crossings, enhanced streetscaping, new sidewalks, and other pedestrian-oriented amenities.

Strengthened North-South Bike Routes

Aldine Street and Prior Avenue are natural north-south bicycle routes through the Fairview Station Area, as both connect northbound cyclists to West Minnehaha Avenue and the Pierce Butler Trail; and south to existing pedestrian and bike crossings over Interstate 94. Each of these routes also intersects with signalized crossings at University Avenue.

Lynhurst Avenue West, which connects the preferred bicycle route on Prior directly to the Fairview LRT platform through Iris Park, and north across the Avenue to the future employment campus, also presents an excellent opportunity to improve north-south bicycle routes.

Strengthened East-West Bike Routes

Two primary east-west bicycle routes, north and south of University Avenue, have been identified through the station area planning process.

North of the Avenue, a future extension of Charles Avenue west from Aldine Street to Wheeler Street is the preferred route for cyclists traveling to/from the direction of the adjacent Snelling Station Area. At Wheeler, the route should be diverted around a future open space and connect with the dormant rail bed located at the northwestern edge of the Station Area, where it then connects to Prior and finally north to West Minnehaha Avenue.

The ability to eventually extend West Minnehaha Avenue westwards over the rail corridor, either through a grade-separated or level crossing, and west to Territorial Road, would provide a critical missing link in the larger regional bicycle network. The long-term feasibility of this large undertaking should be explored.

South of the Avenue, the western leg of the Midtown Greenway and St. Anthony Avenue provides the most direct route east to Snelling Avenue, where it would jog north, connect with Fuller Avenue and eventually reach the State Capitol to the east; and west to the Raymond Station Area and the Wabash Avenue crossing over Highway 280.

Future Bus Service

The Route 16 serves a distinct market apart from the proposed LRT service. When the Route 50 was added it did not diminish the ridership on the Route 16, as the Route 16 is particularly important to those who cannot easily walk long distances – the very young, the very old, those who are transporting goods (i.e. groceries and some durable goods) and/or children, and those who are transit-dependent with physical limitations. Although not uniformly true, most of these patrons need service more during the midday, and on weekends; rather than during the peak hours. Therefore, it is important that the current Route 16 service during the mid-day, evenings and weekends be retained.

The Route 94 service, running between the downtowns will also be retained, but with an abbreviated schedule. The abbreviation of the service should continue to meet the demand for express service between downtown Minneapolis and downtown St. Paul.

As for the specific north-south service, it is essential for north-south service to be bolstered, as current service is insufficient to adequately serve the greater Midway area. The Midway is an area of relatively high residential densities, high transit-dependent populations and numerous jobs. As such, a ½ mile urban grid of transit service is considered essential. To accommodate timed transfers between the 1 mile grid of north-south bus service and LRT, bus service should be no less frequent than meeting the LRT every other train (15 minute frequency) during peak hours. In particular for the Fairview Station Area 15 minute peak-hour and 30 minute non-peak hour minimums on route 67 connecting Minnehaha Avenue and Highland Park are required.

Improved Freeway Crossings

As freeway crossings (with traffic bridges) are redesigned and reconstructed, include widened sidewalks, crash barriers between traffic & sidewalk, pedestrian-level lighting, and approach sidewalk lighting & landscaping. Pedestrian-only freeway crossings should be rebuilt or retrofitted to include well-lit crossings of St. Anthony and Concordia, bridge lighting, and careful landscaping that does not obscure views to and from the bridge.

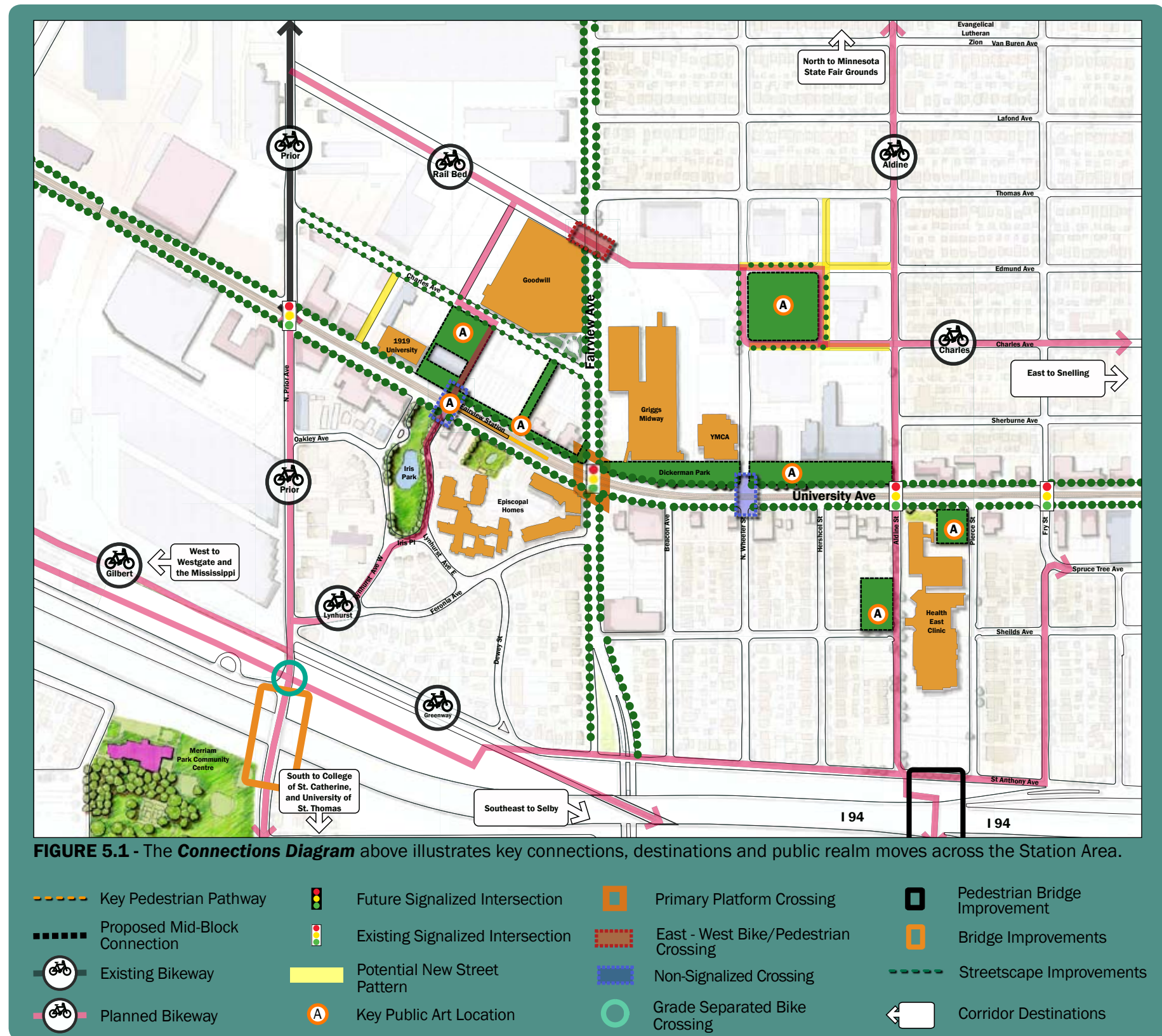

5.2 The Mobility Enhancement Area

The *Mobility Enhancement Area* diagram (figure 5.2) illustrates the current and future hub of movement patterns within the Fairview Station Area.

Mobility Enhancement Area

An opportunity for enhanced mobility around the Fairview Street Station occurs in two key areas. To the north, an opportunity exists to rebalance Charles Street in favor of pedestrians. This will help to transform the street from an access road into a key structuring element and important address for an emerging *Employment Campus* between the 1919 University, Goodwill and Griggs Midway buildings.

Along University Avenue, strategies towards enhancing mobility will focus on a number of fronts including the gradual creation of an *Avenue of Parks*, reclaiming *Dickerman Park* and strengthening the character of the mixed-use corridor.

Special strategies for the Fairview Station Mobility Enhancement Area include:

- Providing enhanced pedestrian crossings at Wheeler Street and special streetscaping that will help to visually and physically link the two sides of Dickerman Park;
- Incorporating special streetscape treatments that work to link the entire *Avenue of the Parks* together from Health East west to Iris Park; and
- Applying an urban streetscape standard along Charles Street to narrow the width of the pavement and create a pedestrian friendly street at the heart of the *Employment Campus* which includes 14 foot sidewalks.

The Station Transfer Zone

The Station Transfer Zone is identified in Figure 5.2. It stretches from Iris Park in the west to Fairview Avenue in the east alongside an expanded green boulevard as part of the proposed *Avenue of Parks*. As such, an opportunity exists to strengthen the park setting of the station and link the various open spaces on either sides of the Avenue to create a station within a park-like setting.

Special strategies for the Fairview Station Transfer Zone include:

- Fully integrating the pedestrian boulevard with the proposed green setback north of University in order to create a unique green corridor along the Avenue;
- Incorporating street and landscape treatments across the Avenue that help to conceptually link Iris Park north across the station platform to the historic Iris Park Place Building; and
- Integrating the Episcopal Homes storm water pond within the streetscape to open the space up to the Avenue, strengthen the park-like setting of the area and further integrate the development back into the life of the Avenue.

The Designated Crossings

Within the Fairview Station Mobility Enhancement Area there are a number of *Designated Crossings*. The *Primary Platform Crossing* is located east of the station platform at Fairview Avenue. It will be the primary area where the LRT links with the city's bus network and form an important link between Dickerman Park and the proposed green setback west of Fairview.

A *Non-Signalized Crossing* is located at the intersection of Lynhurst Avenue and University Avenue. It will be linked directly to the far end of the station platform to provide additional access to the station and provide an important open space connection linking Iris Park north to the proposed employment campus.

Along Fairview Avenue there is an *East - West Bike / Pedestrian Crossing* north of Charles Avenue at the Edmund Avenue alignment. This will help to facilitate a continuous bicycles link from Prior Avenue, east to the Capitol area.

For more detailed descriptions of the various Designated Crossings proposed for the Central Corridor, please refer to Chapter 1 of the full set of Station Area Plans.

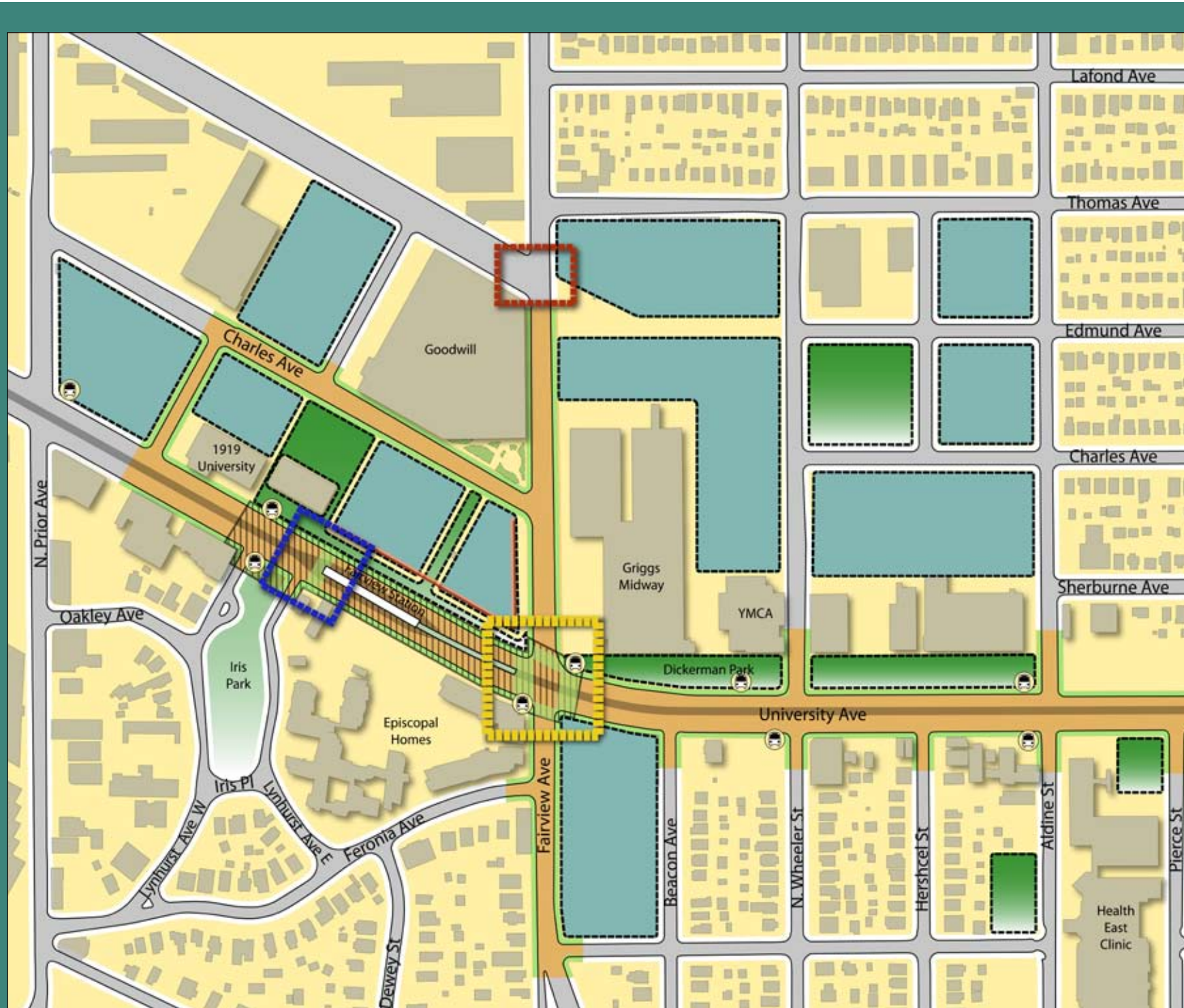











FIGURE 5.2 - The Mobility Enhancement Area illustrates the area around the station where a higher level of pedestrian activity can be anticipated.

-  LRT Platform
-  Mobility Enhancement Area
-  Station Transfer Zone
-  Bus Stop
-  Priority Active Frontage
-  Open Space Candidate Site
-  Future Development Potential
-  Primary Platform Crossing
-  Non-Signalized Crossing
-  East - West Bike / Pedestrian Crossing



Getting There

Achieving the long term objectives set out in this document for the Fairview Station Area will require the collaboration of many local partners, investors and stakeholders, and will occur over time. The following recommendations provide direction on key initiatives that are essential to the success of the future Fairview Station Area.

Using This Station Area Plan

The development concepts illustrated in this plan, including the location of new open spaces, each represent one of many possible development scenarios. Their purpose is to illustrate how the principles and objectives for new development, as contained within the CCDS and this Station Area Plan, could be realized over time. They are not intended to be prescriptive for evaluating future development proposals, but are examples of how the vision, goals, and objectives of this plan can be realized.

Until such time as the City is able to secure necessary resources, either through public investment or through negotiation with private developers for desired new open spaces or other public infrastructure, private property may be used for any legal use permitted under the current zoning classification, provided that the proposed use meets all applicable conditions and/or standards.

Once adopted as a component of the City of Saint Paul's Comprehensive Plan, City staff intend to pursue mechanisms, programs and partnerships that will collectively assist in realizing the vision and objectives created for each station area. The sum of the Central Corridor Development Strategy's 21 Community-Building Strategies (Section 4.3); the Getting There recommendations from individual Station Area Plans (Section 6.0); and the Station Area Plan Chapter 9 - Moving Forward, contain a range of strategies, partnerships and recommendations for assisting in realizing the strategic place-making and economic development potential of this station area.

Securing the Griggs Midway and Charles Commons Green Spaces

As development applications proceed, all future parkland dedication within the Fairview Station Area should be applied to the acquisition of lands for the creation of the "Campus Commons" and Dickerman linear park green spaces. This will require that land dedication be the preferred acquisition approach for future redevelopment of lands immediately adjacent to the proposed location of the park space. Future redevelopment of other parcels within the Station Area should generate cash-in-lieu of dedication for the purpose of acquiring additional lands within both villages. Given the desire to reduce residential and commercial parking standards within the Fairview Station Area, the City may need to pursue an alternate parkland dedication formula here in order to maximize parkland dedication. The potential may exist for these new parks and open spaces to be partially funded through Tax Increment Financing and/or a Regional Transit-Oriented Development "Bank", as described in Chapter 9 Moving Forward.

Western Employment Campus as a TOD Demonstration Site

The City should work with the owners of this collection of parcels to develop a comprehensive master site plan for its future redevelopment. The master plan should reinforce the long term vision laid out in this document, describe the more precise location and configuration of improved pedestrian routes and park spaces, and set detailed guidelines for public realm improvements. All future development applications within this site must demonstrate compatibility with the master plan, clearly indicating how conveyances for public rights-of-way and open space are being met, and how the incremental creation of a normalized block pattern is being achieved. The future viability and success of this site coming forward as a TOD Demonstration Site may in part be assisted through some combination of Tax Increment Financing, the STAR Program, and/or a Regional Transit-Oriented Development "Bank", as described in Chapter 9 Moving Forward.

Establish a Shared Parking Structure

To ensure that the redevelopment and place making potential of this Station Area is not lost through the retention and/or creation of additional surface parking, several locations for shared parking structures should be pursued: on site at the Health East Facility and proximate to the Griggs Midway Building. These structures should be central, above grade facilities or dispersed throughout the Station Area in a series of below grade structures incorporated into employment and mixed-use developments. In this latter instance, public access should be secured to the shared parking facility through a Municipal Parking Authority for some portion of the structure; or through the creation of a long-term lease with a commercial parking operator.

Transition Over Time

Meeting the full development potential of the Central Corridor, as conceptually illustrated in each Station Area Plan, will occur over a long period of time. Recognizing the market may not be uniformly ready to respond to the ambitious visions illustrated in each plan nor to the full extent of the Transit Opportunity Zone (TOZ) regulatory framework outlined in the Central Corridor Development Strategy, both sets of policy documents should allow for market transformation and uptake over time.

For example, a near-term development proposal that does not meet density expectations for central, strategic sites, or does not secure a shared parking agreement with a neighboring land owner, yet meets other long-term objectives such as increasing the range of available housing types, supporting economic development, increasing retail options and employment opportunities, or providing active uses at grade, should be accommodated. In these instances, proponents of development applications should demonstrate how specific physical and/or market constraints make the full range of station area objectives difficult to achieve, how the general intent and purpose of the CCDS and respective Station Area Plan will be met, and additionally how other standards are being met and/or exceeded.

The development principles matrix, outlined in Chapter 9, may also assist City officials, staff, and community members in evaluating the benefits of development proposals in terms of economic value and transit-supportive principles included in the CCDS.

Please refer to Chapter 9 - Moving Forward of the full set of Station Area Plans for additional details.

Involving Local Partners

Meeting the long-term objectives of the Fairview Station Area Plan will require coordination with:

Major land owners, with reinvestment interests, including Griggs Midway, Goodwill and 1919 University Avenue.

Union Park District Council & Hamline-Midway Coalition.

To review development applications coming forward, promote and work towards quality development projects and meet with residents, institutions, business and property owners to discuss and document evolving community concerns and objectives for new development.

Saint Paul Port Authority. A significant portion of the infill and redevelopment potential within the Fairview Station Area will require direct consultation with the Saint Paul Port Authority.

St. Paul Smart Trips. As the Transportation Management Organization for the City, Smart Trips should work with local partners to provide information about parking in the corridor, and to promote opportunities for walking, bicycling, and transit.

Midway-Chamber, University Avenue Business Association and other business groups. To ensure the interests of area businesses and property owners are adequately represented through comprehensive policy framework reviews.

University UNITED. To assist in the ongoing review of development applications in conjunction with District Council offices, and to continue enriching dialogues around improving the character and quality of area planning and development.

Central Corridor Funders Collaborative. To assist in securing resources for community improvement projects.

Individual property owners. Consultation and discussion should begin well in advance of submission of development applications, and continue through the development approvals process.

The Central Corridor Design Center. The Central Corridor Design Center is an initiative by the City of Saint Paul to apply the proven practices of the Saint Paul on the Mississippi Design Center along the Central Corridor. Its mission is to be a champion and advocate for the principles and vision of the Central Corridor Development Strategy as they guide public and private investment in the corridor. U-Plan, a program of University UNITED, will provide technical support services to community groups, small businesses, and other stakeholders.

The CCDC will be involved in design review and guidance of the Central Corridor LRT and other public realm improvements; design development conversations with large and small property owners; technical assistance to small businesses to redesign their facilities to take advantage of the LRT and proposed public improvements; providing leadership in energy and environmental design; and education and training of City staff, consultants, developers and property owners in maximizing transit-oriented design opportunities along the Corridor and in the neighborhood.